

PLANTS vs. ZOMBIES

The Last Stand



IMPORTANT

- Before using this product, read this manual carefully to understand the contents herein stated.
- After reading this manual, be sure to keep it near the product or in a convenient place for easy reference when necessary.

BEFORE USING THE PRODUCT, BE SURE TO READ THE FOLLOWING:

To maintain safety:

To ensure the safe operation of this product, be sure to read the following before usage.

The following instructions are intended for the users, operators and the personnel in charge of the operation of the product. After carefully reading and sufficiently understanding the warning displays and cautions, handle the product appropriately. Be sure to keep this manual close to the product or in a convenient place for future reference.

Herein, explanations which require special attention are enclosed with dual lines. Depending on the potentially hazardous degrees, the terms of DANGER, WARNING, CAUTION, etc. are used. Be sure to understand the contents of the displays before reading the text.

 **DANGER** Indicates that mishandling the product by disregarding this pictograph will cause severe injury or death.

 **WARNING** Indicates that mishandling the product by disregarding this warning will cause a potentially hazardous situation which can result in death or serious injury.

 **CAUTION** Indicates that mishandling the product by disregarding this caution will cause a slight hazardous situation which can result in personal injury and/or material damage.

For the safe usage of the product, the following pictographs are used:



Indicates "HANDLE WITH CARE." In order to protect the human body and equipment, this display is attached to places where the Owner's Manual, Serviceman Manual and/or Service Manual should be referred to.

- **Perform work in accordance with the instructions herein stated.** Instructions for work are explained by paying attention to the aspect of accident prevention. Failing to perform work as per the instructions can cause accidents. In the case where only those who have technical expertise should perform the work to avoid hazardous situation, the instructions herein state that the site maintenance personnel should perform such work.
- **Be sure to turn off the power before working on the machine.** To prevent an electric shock, be sure to turn off the power before carrying out any work that requires direct contact with the interior of the product. If the work is to be performed in the power-on status, the Instruction Manual herein always states to that effect.
- **Be sure to ground the Earth Terminal.** (This is not required in the case where a power cord with earth is used.)
- **This product is equipped with the Earth Terminal.** When installing the product, connect the Earth Terminal to the "accurately grounded indoor earth terminal" by using an earth wire. Unless the product is grounded appropriately, the user can be subject to an electric shock. After performing repair, etc. for the control equipment, ensure that the Earth Wire is firmly connected to the control equipment.
- **Ensure that the Power Supply used is equipped with an Earth Leakage Breaker.** This product does not incorporate the Earth Leakage Breaker. Using a power supply which is not equipped with the Earth Leakage Breaker can cause a fire when earth leakage occurs.
- **Be sure to use fuses which meet the specified rating.** (Only for the machines which use fuses.) Using fuses exceeding the specified rating can cause a fire and an electric shock. (Only for the machines which use fuses.) Using fuses exceeding the specified rating can cause a fire and an electric shock.

- **Specification changes (removal of equipment, conversion and addition) not designated by SEGA are not allowed.** The parts of the product include warning labels for safety, covers for personal protection, etc. It is very hazardous to operate the product by removing parts and/or modifying the circuits. Should doors, lids and protective parts be damaged or lost, refrain from operating the product, and contact where the product was purchased from or the office herein stated. SEGA shall not be held responsible for any accidents, compensation for damage to a third party, resulting from the specifications not designated by SEGA.
- Ensure that the product meets the requirements of appropriate electrical specifications. Before installing the product, check for electrical specifications. SEGA products have a nameplate on which electrical specifications are described. Ensure that the product is compatible with the power supply voltage and frequency requirements of the location. Using any electrical specifications different from the designated specifications can cause a fire and an electric shock.
- Install and operate the product in places where appropriate lighting is available, allowing warning labels to be clearly read. To ensure safety for the customers, labels and printed instructions describing potentially hazardous situations are applied to places where accidents can be caused. Ensure that where the product is operated has sufficient lighting allowing the warnings to be read. If any label is peeled off, apply it again immediately. Please place an order with where the product was purchased from or the office herein stated.
- When handling the monitor, be very careful. (Applies only to products with monitors.) Some of the monitor parts are subject to high tension voltage. Even after turning off the power, some portions are still subject to high tension voltage sometimes. Monitor repair and replacement should be performed only by those technical personnel who have knowledge of electricity and technical expertise.
- Be sure to adjust the monitor properly. (Applies only to products with monitors.) Do not operate the product leaving on-screen flickering or blurring as it is. Using the product with the monitor not properly adjusted may cause dizziness or a headache to an operator, a player, or the customers.
- When transporting or reselling this product, be sure to attach this manual to the product.
- *In the case where commercially available monitors and printers are used in this product, only the contents relating to this product are explained herein. Some commercially available equipment has functions and reactions not stated in this manual. Read this manual together with the specific instruction manual of such equipment.*
- *Descriptions herein contained may be subject to improvement changes without notice.*
- *The contents described herein are fully prepared with due care. However, should any question arise or errors be found, please contact SEGA.*

INSPECTIONS IMMEDIATELY AFTER TRANSPORTING THE PRODUCT TO THE LOCATION

Normally, at the time of shipment, SEGA products are in a status allowing for usage immediately after transporting to the location. Nevertheless, an irregular situation may occur during transportation. Before turning on the power, check the following points to ensure that the product has been transported in a satisfactory status.

- Are there any dented portions or defects (cuts, etc.) on the external surfaces of the cabinet?
- Are casters and adjusters damaged?
- Do the power supply voltage and frequency requirements meet with those of the location?
- Are all wiring connectors correctly and securely connected? Unless connected in the correct way, connector connections can not be made accurately. Do not insert connectors forcibly.
- Do power cables have cuts and dents?
- Are all accessories available?
- Can all doors and lids be opened with the accessory keys? Can doors and lids be firmly closed?

INTRODUCTION

This manual is intended to provide detailed descriptions together with all necessary information covering the general operation of electronic assemblies, electro-mechanicals, servicing control, spare parts, etc. for the product, "PLANTS VS ZOMBIES."

This manual is intended for the owners, personnel managers in charge of operation of this product. Operate the product after carefully reading and sufficiently understanding the instructions.

In the unlikely event that the product does not function correctly, DO NOT allow anyone other than a technician to touch the internal system. Turn off the power to the machine, making sure to unplug the electrical cord from the outlet, and contact the office listed below or the point-of-purchase for this product.

Use of this product is unlikely to cause physical injuries or damage to property. However, points that require special attention are indicated by bold text, the word "IMPORTANT" and the symbol below.

IMPORTANT

Indicates important information that, if ignored, may result in the mishandling of the product and cause faulty operation or damage to the product.

Sega Amusements Europe Limited.

42 Barwell Business Park, Leatherhead Road, Chessington, Surrey, KT9 2NY. United Kingdom.

Telephone: +44 (0) 208 391 8090 Facsimile: +44 (0) 208 391 8099
email: sales@segaarcade.com Web: <http://www.segaarcade.com>.

Sega Total Solutions

42 Barwell Business Park, Leatherhead Road, Chessington, Surrey, KT9 2NY. United Kingdom.

Telephone: +44 (0) 208 391 8060 Facsimile: +44 (0) 208 391 8096
email: sales@segaarcade.com Web: <http://www.segaarcade.com/spares>

Play it! Amusements

252 Beinoris Drive, Wood Dale, IL. 60191, USA

USA Sales/Service +00(1) 224 265 4287

SPECIFICATIONS

CABINET

Machine Dimensions: (39.972 in.) [Width] x (74.035 in.) [Depth]
Machine Height: (97.464 in.) (Installed)
Machine Weight: 470 lbs (Packaged)
Marquee Weight 37 lbs.
Seat Weight 42 lbs.
Monitor Cab Weight 321

Power, maximum current: 220v ~1.5 AMP

Definition of 'Site Maintenance Personnel or Other Qualified Individuals'**STOP IMPORTANT**

Procedures not described in this manual or marked as 'to be carried out by site maintenance personnel or other qualified professionals' should not be carried out by personnel without the necessary skill or technology. Work carried out by unqualified persons may cause serious accidents, including electrocution.

Parts replacement, maintenance inspections and troubleshooting should be carried out by site maintenance personnel or other qualified professionals. This manual includes directions for potentially dangerous procedures which should only be carried out by professionals with the appropriate specialised knowledge.

The site maintenance personnel or other qualified professionals mentioned in this manual are defined as follows:

Site maintenance personnel:

Individuals with experience in maintaining amusement equipment, vending machines, etc., working under the supervision of the owner/operator of this product to maintain machines within amusement facilities or similar premises by carrying out everyday procedures such as assembly, maintenance inspections, and replacement of units/expendable parts.

Activities to be carried out by site maintenance personnel:

Amusement equipment/vending machine assembly, maintenance inspection and replacement of units/expendable parts.

Other qualified professionals:

Persons employed by amusement equipment manufacturers, or involved in design, production, testing or maintenance of amusement equipment. The individual should have either graduated from technical school or hold similar qualifications in electrical/electronics/mechanical engineering.

Activities to be carried out by other qualified professionals:

Amusement equipment/vending machine assembly, repair/adjustment of electrical/electronic/mechanical parts.

Waste of Electrical and Electronic Equipment (WEEE) Statement.

The WEEE (Waste of Electrical and Electronic Equipment) directive places an obligation on all EU based manufacturers and importers of Electrical and Electronic Equipment to take back products at the end of their useful life. Sega Amusements Europe Ltd accepts its responsibility to finance the cost of treatment and recovery of redundant WEEE in the United Kingdom in accordance with the specified WEEE recycling requirements.

The symbol shown below will be on all products manufactured from 13th August 2005, which indicates this product must NOT be disposed of with other normal waste. Instead, it is the user's responsibility to dispose of their waste equipment by arranging to return it to a designated UK collection point for the correct recycling of waste electrical and electronic equipment.

For more information about where you can send your waste equipment for recycling contact your local authority office.

For non-UK users contact your local authority office for information on the recycling of Waste Electrical and Electronic Equipment.

Battery Recycling Statement.

The EC Directive on Batteries and Accumulators (2006/66/EC) aims to minimise the impact of batteries on the environment and encourage the recovery of the materials they contain. To achieve increased collection and recycling of waste batteries, the Directive places 'producer responsibility' obligations on manufacturers and importers of portable, industrial and automotive batteries.

The symbol shown below will be on all equipment fitted with batteries from 26th September 2008 and indicates they must NOT be disposed of with other normal waste. Instead, it is the user's responsibility to dispose of used batteries by arranging to return them to a designated collection point for the correct recycling.

For more information about where you can send your waste batteries for recycling contact your local authority office.



REGISTERED IN ENGLAND REGISTERED NO. 1711515

REGISTERED OFFICE: BLOCK C 42 BARWELL BUSINESS PARK, CHESSINGTON, SURREY KT9 2NY

TABLE OF CONTENTS

INTRODUCTION	i-vii
1 HANDLING PRECAUTIONS	1-3
2 PRECAUTIONS REGARDING INSTALLATION	4-6
3 PRECAUTIONS REGARDING OPERATION	7-9
4 PARTS DESCRIPTION	10-12
4-1 FIXATION TO SITE	10
4-2 POWER SUPPLY	11
5 GAME DISCRPTION	13-17
6 TEST MODE	18-34
6-1 TEST MODE	18
6-2 SYSTEM INFORMATION	19
6-3 BOOKKEEPING	26
6-4 SETTING THE CLOCK	30
6-5 GAME SETTINGS	31
7 CONTROLLER UNIT	34-40
7-1 CONTROLLER UNIT	35
7-2 ADJUSTING VOLUME POT	37
7-3 GREASING	40
8 LCD/PLASMA DISPLAY	41-42
8-1 SAFETY HANDLING MONITOR	41
8-2 CLEANING SCREEN	42
9 COIN HANDLING	43-46
9-3 CLEANING THE COIN SELECTOR	43
9-3 FAULT FINDING	46
10 PERIODIC INSPECTION	47-48
11 GAME BOARD	49-50
11-1 GAMEBOARD LOCATION AND REMOVAL	50
12 ART RELATED PARTS	53-54
13 PART DESCRIPTION	55-62
14 WIRING DIAGRAMS	63-64

1 HANDLING PRECAUTIONS

When installing or inspecting the machine, be very careful of the following points and pay attention to ensure that the player can enjoy the game safely.

Noncompliance with the following points or inappropriate handling running counter to the cautionary matters herein stated can cause personal injury or damage to the machine.

WARNING

Before performing work, be sure to turn the power off. Performing the work without turning the power off can cause an electric shock or short circuit. In cases where work should be performed in the status of power on, this manual always states to that effect.

To avoid an electric shock or short circuit, do not plug in or unplug quickly.

To avoid an electric shock, do not plug in or unplug with a wet hand.

Do not expose power cords or earth wires on the surface, (floor, passage, etc.) If exposed, the power cords and earth wires are susceptible to damage. Damaged cords and wires can cause an electric shock or short circuit.

To avoid causing a fire or an electric shock, do not put things on or damage the power cords.

When or after installing the product, do not unnecessarily pull the power cord. **If damaged, the power cord can cause a fire or an electric shock.**

In case the power cord is damaged, ask for a replacement through where the product was purchased from or the office herein stated. **Using the cord as is damaged can cause fire, an electric shock or leakage.**

Be sure to perform grounding appropriately. Inappropriate grounding can cause an electric shock.

Be sure to use fuses meeting the specified rating. Using fuses exceeding the specified rating can cause a fire or an electric shock.

Be sure that connections such as IC BD are made properly. Insufficient insertion can cause an electric shock.

Specification changes, removal of equipment, conversion and/or addition, not designated by SEGA are not permitted.

Failure to observe this may cause a fire or an electric shock. **Non-compliance with this instruction can have a bad influence upon physical conditions of the players or the onlookers, or result in injury during play.**

SEGA shall not be held responsible for damage, compensation for damage to a third party, caused by specification changes not designated by SEGA.

Do not perform any work or change parts not listed in this manual. Doing so may lead to an accident.

If you need to perform any work not listed in this manual, request work from the office indicated in this manual or the point of purchase, or inquires for details.

Be sure to perform periodic maintenance inspections herein stated.

STOP IMPORTANT

For the IC board circuit inspections, only the use of a logic tester is recommended. Using a Multi Tester or General Purpose Tester may result in damage to IC Circuits.

Static electricity from your body may damage some electronics devices on the IC board. Before handling the IC board, touch a grounded metallic surface so that the static electricity can be discharged.

This video gaming cabinet utilises a motorised steering feedback system. Do not attempt to service this part or any other part in close proximity to the steering mechanism whilst power is applied.

Some parts are not designed and manufactured specifically for this game machine. **The manufacturers may discontinue, or change the specifications of such general-purpose parts.** If this is the case, SEGA cannot repair or replace a failed game machine whether or not a warranty period has expired.

CONCERNING THE STICKER DISPLAY

This SEGA product has stickers attached describing the product manufacture No. (Serial No.) and Electrical Specifications. It also has a Sticker describing where to contact for repair and for purchasing parts. When inquiring about or asking for repairs, mention the Serial No. and Name of Machine indicated on the Sticker. The Serial Number indicates the product register. Identical machines could have different parts depending on the date of production. Also, improvements and modifications might have been made after the publication of this manual. In order to ensure you order the correct parts, mention the Serial No. when contacting the applicable places.

CONCERNING WARNING DISPLAYS

This SEGA product has warning displays on stickers, labels and/or printed instructions adhered/attached to or incorporated in the places where a potentially hazardous situation could arise. The warning displays are intended for accident prevention for customers and for avoiding hazardous situations relating to maintenance and servicing work. Some portions of the cabinet contain high voltage and may cause accidents if touched. When performing maintenance, be very careful of the warning displays. It is especially important that any complex repair and replacement work not mentioned herein should be performed by those technical personnel who have knowledge of electricity and technical expertise.

In order to prevent accidents, caution any customer ignoring the warnings to cease and desist immediately.

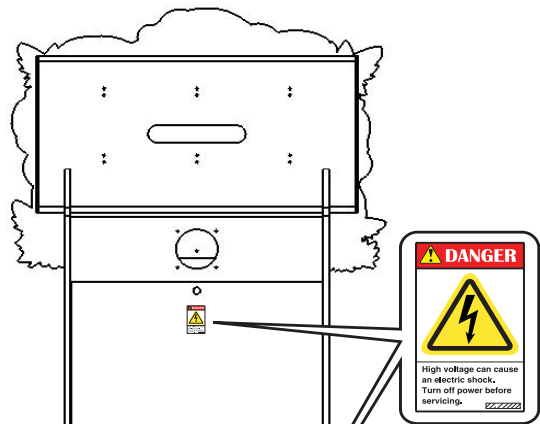
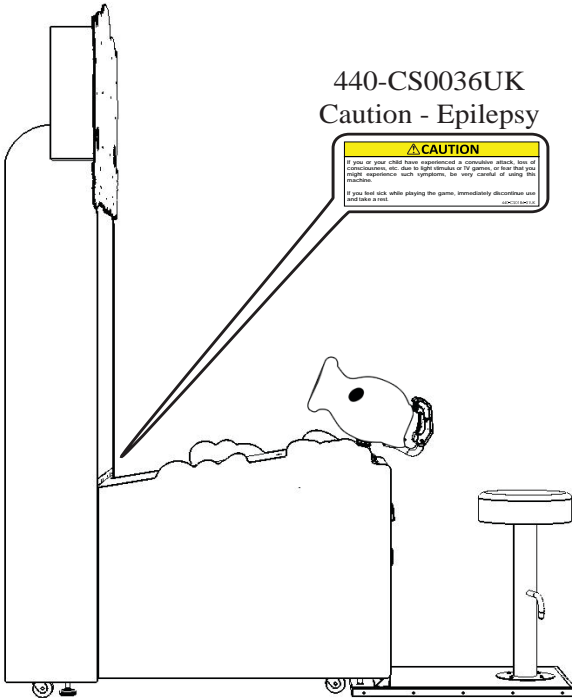

440-DS0010UK
Hi-Voltage

CAUTION: DISCONNECT SUPPLY CORD BEFORE CHANGING FUSE.
ATTENTION: DÉBRANCHER AVANT DE REPLACER LE FUSIBLE.

Fuse Warning

Caution: For continued protection against risk of fire. Replace only with the same type of fuse having the same electrical ratings.
Attention: Utiliser un fusible de rechange de meme type.
250V 5,0 Amps SLO

Fuse Ratings and Caution

P.A.T. Label

PORTABLE APPLIANCE TEST RECORD

TEST DATE	TESTER NAME	CLASS	APPROVED BY	TEST	REMARKS

PLANTS VS ZOMBIES
Model: 601-00-001
SN#:120002
120V 60Hz 5 AMP
For Indoor Use Only

Ratings/Serial

2 PRECAUTIONS REGARDING INSTALLATION

WARNING

This product is an indoor game machine. Do not install it outside. Even indoors, avoid installing in places mentioned below so as not to cause a fire, electric shock, injury and/or malfunction.

Places subject to rain or water leakage, or places subject to high humidity in the proximity of an indoor swimming pool and/or shower, etc.

Places subject to direct sunlight, or places subject to high temperatures in the proximity of heating units, etc.

Places filled with inflammable gas or vicinity of highly inflammable/volatile chemicals or hazardous matter.

Dusty places.

Sloped surfaces.

Places subject to any type of violent impact.

Vicinity of anti-disaster facilities such as fire exits and fire extinguishers.

Areas where the temperature exceeds the applicable temperature (ambient temperature) range of 5 to 30 degrees centigrade.

LIMITATIONS OF USAGE

WARNING

Be sure to check the Electrical Specifications. Ensure that this product is compatible with the location's power supply, voltage, and frequency requirements. A plate describing Electrical Specifications is attached to the product. **Non-compliance with the Electrical Specifications can cause a fire and electric shock.**

This product requires a breaker and earth mechanism as part of the location facilities. **Using the product without these can cause a fire and electric shock.**

Ensure that the indoor wiring for the power supply is rated at 15 A or higher (AC single phase 100 V ~ 120 V area), and 7 A or higher (AC 220 V ~ 240 V area). **Non-compliance with the Electrical Specifications can cause a fire and electric shock.**

Be sure to use an independent power supply equipped with an earth leakage breaker. Using a power supply without an earth leakage breaker can cause an **outbreak of fire if a power surge occurs.**

Putting many loads on one electrical outlet can cause generation of heat and a **fire resulting from overload.**

When using an extension cord, ensure that the cord is rated at 15 A or higher (AC 100 V ~ 120 V area) and 7 A or higher (AC 220 V ~ 240 V area). Using a cord rated lower than the specified rating can cause a fire and electric shock.

STOP IMPORTANT

Securing a safe area for operation as described in this manual will ensure safe operation for players and observers.

SEGA shall not be held responsible for damage or compensation for damage to a third party, resulting from the failure to observe this instruction.

OPERATION AREA (SINGLE CABINET)

WARNING

For the operation of this machine, please secure a minimum area of 2.10m (D) and 1.10m (W)

Be sure to provide sufficient space specified in this manual. Do not allow objects to block the ventilation ports. It can cause generation of heat and a fire.

Sufficient space either side of the playing area must be allowed for the player to enter or exit the game safely.

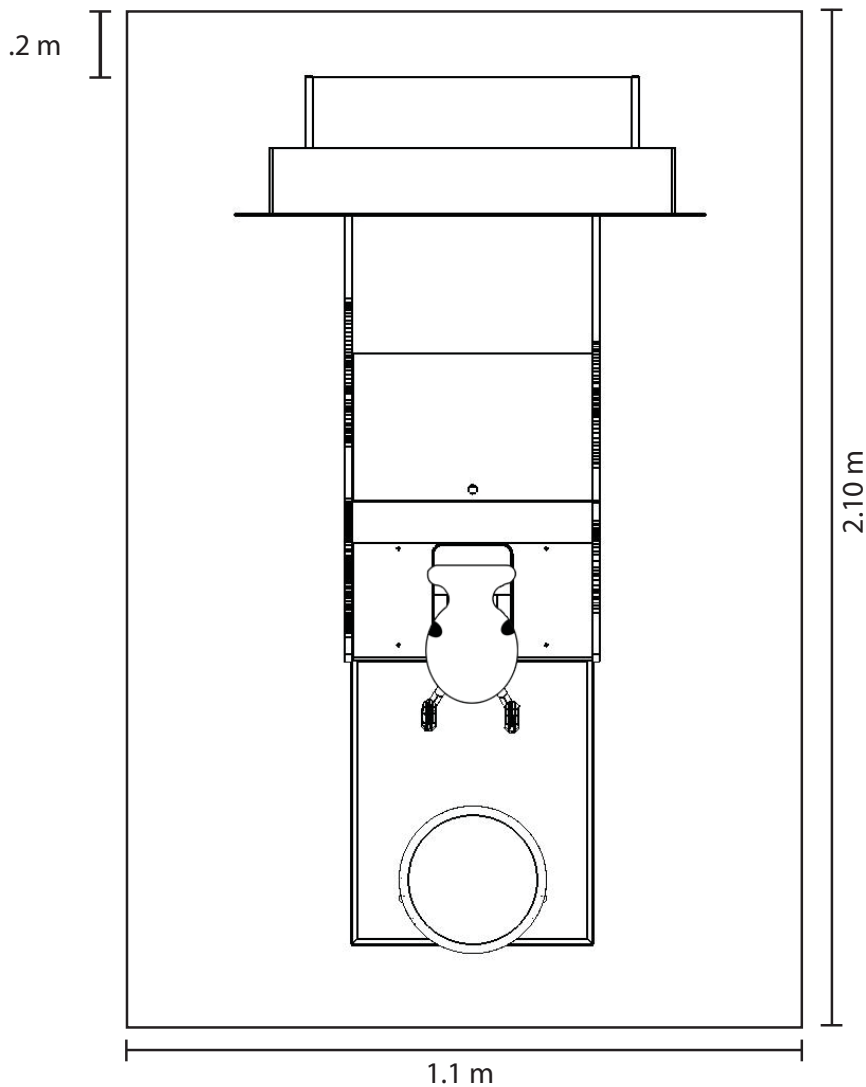

STOP IMPORTANT

To install this product, the entrance must be at least 73.7 cm in width and 200.7 cm in height (29x79 inches).

Do not attempt to push/pull the machines whilst holding onto the Controller or Assy Billboard. This may result in part damage and or personal injury.

2 PRECAUTIONS REGARDING INSTALLATION LOCATION

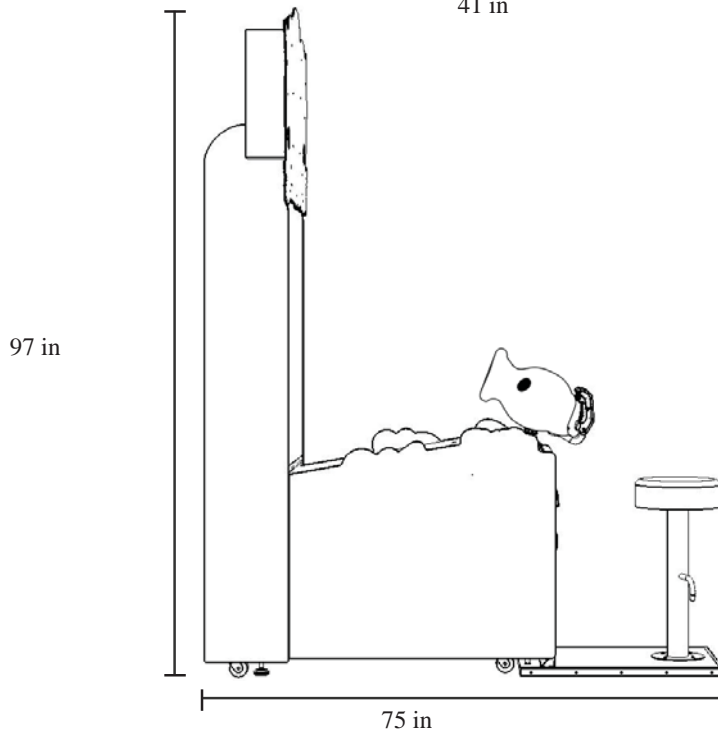
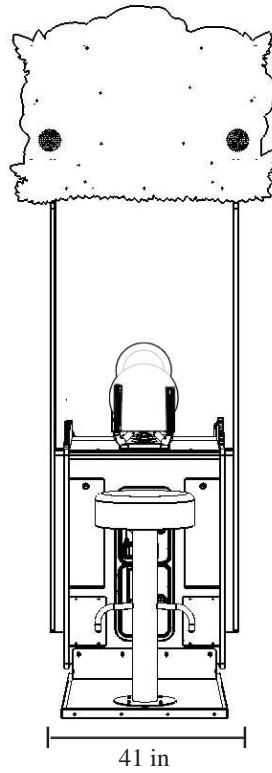

3 PRECAUTIONS REGARDING OPERATION

To avoid injury and trouble, be sure to pay attention to the behavior of visitors and players.

WARNING

In order to avoid accidents, check the following before starting the operation:

- To ensure maximum safety for the players and the customers, ensure that where the product is operated has **sufficient** lighting to allow any warnings to be read. Operation under **insufficient** lighting can cause bodily contact with each other, hitting accident, and/or trouble between customers.
- Be sure to perform appropriate adjustment of the display (LCD, Plasma, CRT or Projector). For operation of this machine, do not leave monitor's **flickering** or deviation as is. Failure to observe this can have a **bad influence** upon the players' or the customers' physical conditions.
- It is suggested to ensure a space allowing the players who feel sick while playing the game to take a rest.
- Check if all of the adjusters are in contact with the surface. If they are not, the Cabinet can move and cause an accident.
- Do not put any heavy item on this product. Items, if placed on this product may fall and cause injury to the player / observer.
- Do not climb on the product. Climbing on the product can cause falling down accidents. To check the top portion of the product, use a step ladder.

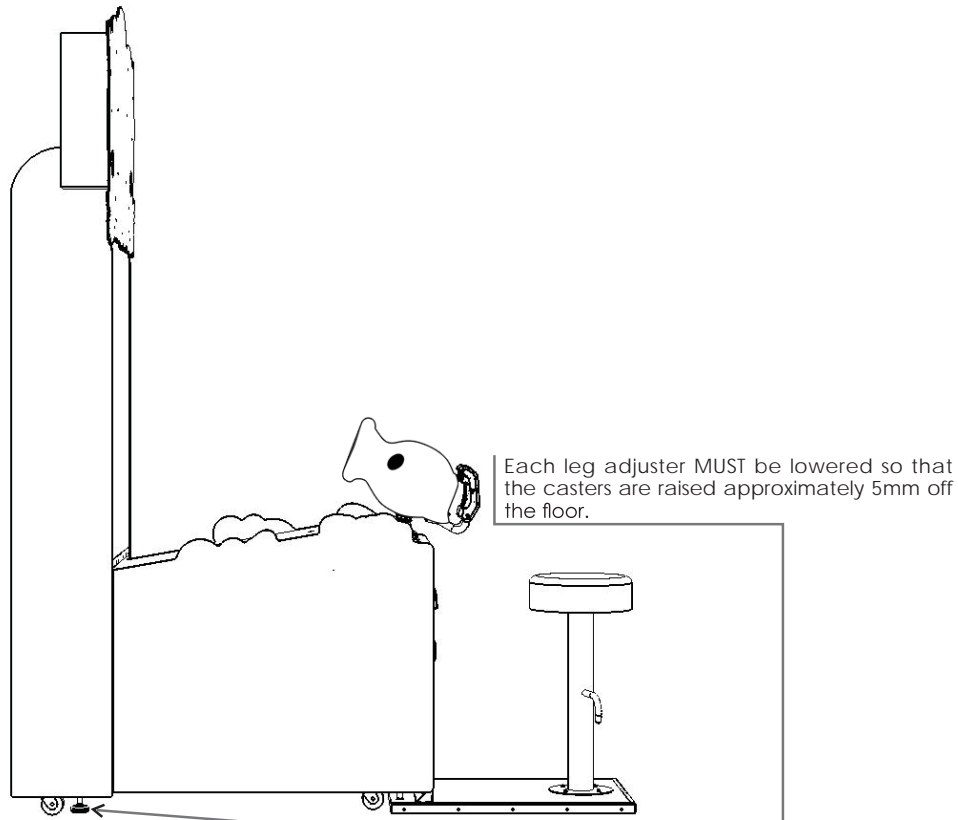

⚠ WARNING

- To avoid electric shock, ensure that all covers and panels are undamaged and fitted. Do not operate with covers removed.
- To avoid electric shock, short circuit and/or parts damage, do not put the following items on or in the periphery of the product.
- Flower vases, flowerpots, cups, water tanks, cosmetics, and receptacles/containers/vessels containing chemicals and water.

⚠ CAUTION

- To avoid injury, be sure to provide sufficient space by considering the potentially crowded situation at the installation location. Insufficient installation space can cause making bodily contact with each other, hitting accidents, and/or trouble between customers.
- Everyday when cleaning the Controller, inspect the controller and make sure that there are no cracks in the surface, and that the fastening screws are not loose. If the game is played with cracks or loose screws, it can cause injuries to the player.

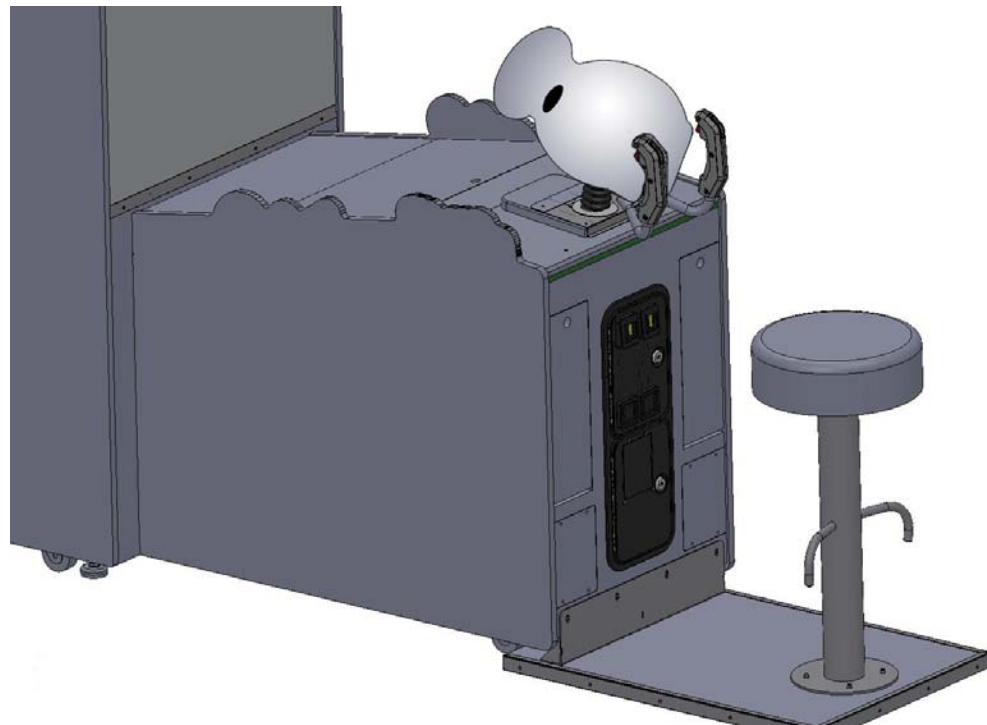

DURING OPERATION (PAYING ATTENTION TO CUSTOMERS)

To avoid injury and trouble, be sure to constantly give careful attention to the behavior and manner of the visitors and players.

WARNING

- For safety reasons, do not allow any of the following people to play the game.
- Those who have high blood pressure or a heart problem.
- Those who have experienced muscle convulsion or loss of consciousness when playing video games, etc.
- Those who have neck or spinal cord problems.
- Those who are intoxicated or under the influence of drugs.
- Pregnant women.
- Those who are not in good health.
- Those who do not follow the attendant's instructions.
- Those who cannot grasp the Control Unit securely because of immobility in fingers, hands or arms.
- Persons who disregard the product's warning displays.
- This product is intended for a single player only. Having two or more persons simultaneously playing this product can result to injury to the player and possible damage to the product.
- Even players who have never been adversely affected by light stimulus might experience dizziness or headache depending on their physical condition when playing the game.
- Small children are especially likely to experience these symptoms. Caution guardians of small children to keep watch on their children during play.
- Instruct those who feel sick during play to have a medical examination.
- To avoid injury from falls and electric shocks due to spilled drinks, instruct the player not to place heavy items or drinks on the product.
- To avoid electric shocks and short circuits, do not allow customers to put hands and fingers or extraneous matter in the openings of the product or small openings in or around the doors.
- To avoid falls and resulting injury, immediately stop the customer from leaning against or climbing on the product, etc.
- To avoid electric shock and short circuit, do not allow customers to unplug the power plug without a justifiable reason.
- Instruct the guardians of small children to keep an eye on their children.
- Children cannot sense danger. Allowing small children to get near a player who is playing the game could result in the children being bumped, struck or knocked down.

4-1 FIXATION TO SITE

⚠ WARNING

- Make sure that all the adjusters contact the floor. Otherwise the cabinet could move, causing an accident.
- Provide a ventilation space at least 20cm wide behind the cabinet. There are ventilation holes on the back of the cabinet. Do not block the ventilation holes. Doing so could trap heat inside resulting in fire. It could also result in equipment damage or cause parts to become exhausted prematurely.

The product is equipped with 4 casters and 2 adjusters.

When installation position / site has been determined, have the adjusters come in direct contact with the floor. Establish a gap of about 5 mm between the floor and the casters and adjust the unit so that it will remain level.

1 Move the product to the installation site.

2 Bring the adjusters into direct contact with the floor. Use a wrench to align the height of the adjusters until the cabinet is perfectly level.

3 After setting, turn adjuster nuts upwards to tighten them and secure adjuster heights.

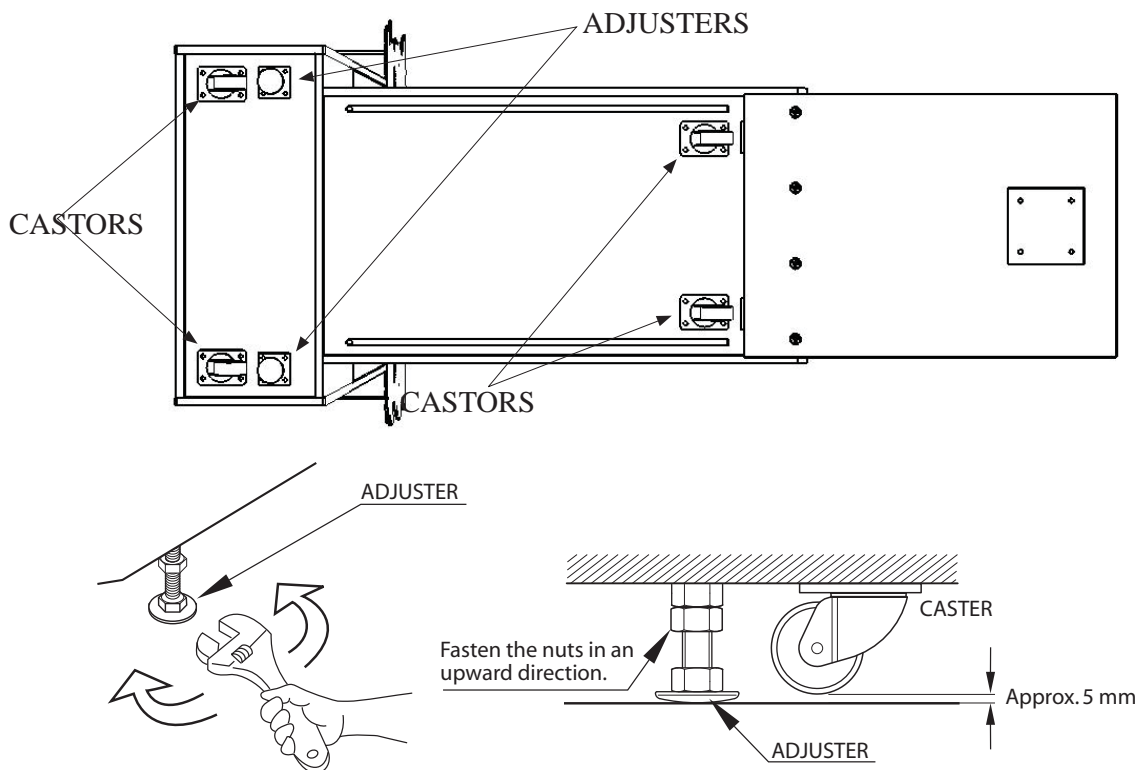

4-2 POWER SUPPLY AND OTHER CONNECTIONS

4

ASSEMBLY AND INSTALLATION

⚠ WARNING

- Use the power supply equipped with an earth leakage breaker. Use of power supply without such a breaker could result in fire if there is a current leakage.
- Have available a securely grounded indoor ground terminal. Without proper grounding, customers could be electrocuted and product operations might not always be stable.
- Do not expose the power cord or ground wire. If these are exposed, customers could stumble over them, for instance, and easily damage them. Additionally, if these lines are damaged, there could be a risk of electrical shock or short circuit. Set these lines at locations where they will not interfere with customer traffic, or attach covers to them.
- After laying out the power cord on the floor, be sure to always protect it. If the power cord is left exposed, it can easily be damaged, resulting in electrical shock.

1 Confirm that the main switch is at OFF.



FUSE

POWER SWITCH

POWER INPUT

2 Fully insert the power cord connector on the side opposite the power plug into the AC unit IEC inlet. Insert the power cord plug into the outlet.

3 The power code is laid out indoors. Protect the power cord by attaching wire cover to it.

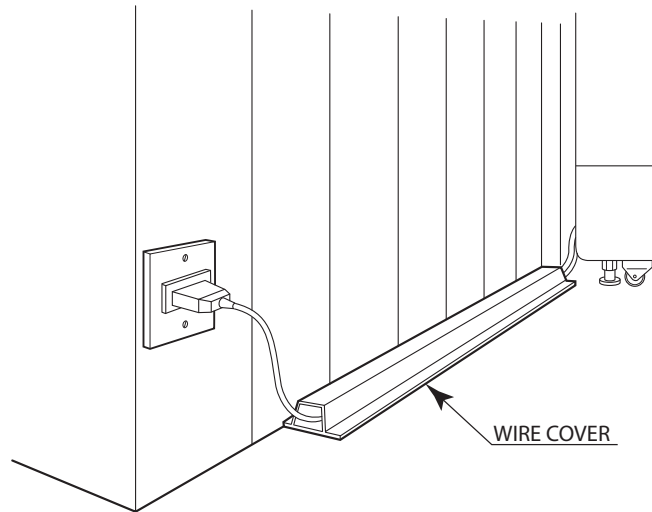

5 GAME DESCRIPTION AND SOFTWARE



Game Overview

The smash hit PC and mobile tower defense game has come to the arcade in an all new 3D World!

Plants vs. Zombies™ The Last Stand (PvZ: TLS) puts the player at the control of a cabinet mounted Peashooter that is used to zap advancing waves of zombies with peas. If any Zombie crosses the players last line of defense, its game over. If all Zombie waves are destroyed the player wins.

Name Entry

Once a credit has been inserted (or the SERVICE BUTTON has been pressed to give a service credit) the player will be asked to enter their initials.

The player can do this by using the crosshair on screen and pulling the trigger on the Peashooter. If the player fails to enter their initials in the allotted time, or enters a forbidden combination they will be assigned 'PLA'.

Once 3 letters have been entered the screen will automatically move on to the WAIT/Start screen.



Wait/Start

On this screen the player has the option to begin their game by selecting the tombstone with the inscription 'SHOOT TO START' or to select the secret unlock tombstone with the inscription 'CEASED TO EXIST'.

Both options are selected using the crosshair on screen and pulling the trigger on the Peashooter.

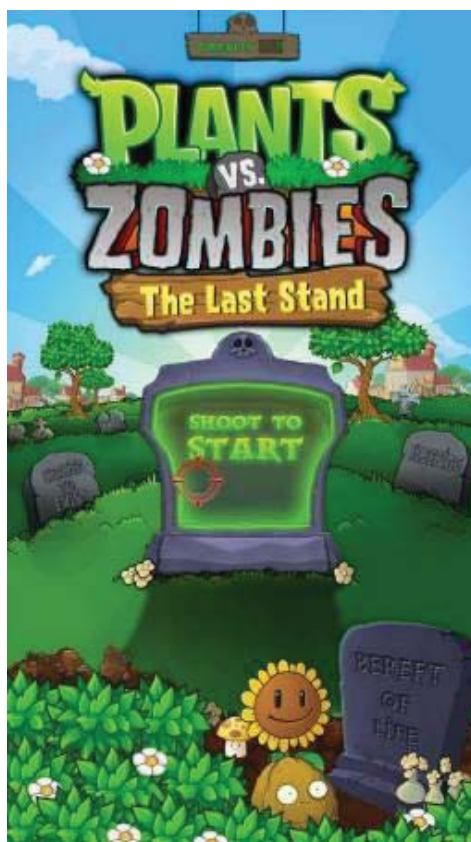

Unlock Screen

An Unlock Code can be entered into this screen using the crosshair on screen and pulling the trigger on the Peashooter.

Unlock codes are distributed in various ways, including playing PvZ: TLS and registering a high score on the Sega Scores website. For more information please visit www.segascores.com or www.segaarcade.com.

Upon entering a correct 4-digit code the player will be shown an Award Card and receive an audio recognition, and the game will begin.

If entering an incorrect code the player will receive a denial audio, and the game will be begin.

Unlock Codes are used to change the aesthetics of the Game, and in no way alter the settings predefined in the Test and Service menu.



Game

At the beginning of each game a map of the PvZ: TLS world will appear and Crazy Dave will alert you to where the Zombies are hiding.

After a short intro video showing you the positioning of the Zombies and the LAST Peashooter (controlled by the player) the game begins.

How to play

- Zap the Zombies as they approach using the Peashooter.
- Stop them from reaching the Peashooter. (Yes, it's as simple as that!)



Game Over

The game can end in 1 of 2 ways.

Defeating all of the Zombies

Or

The Zombies eat your Brains! (you don't want this to happen!).

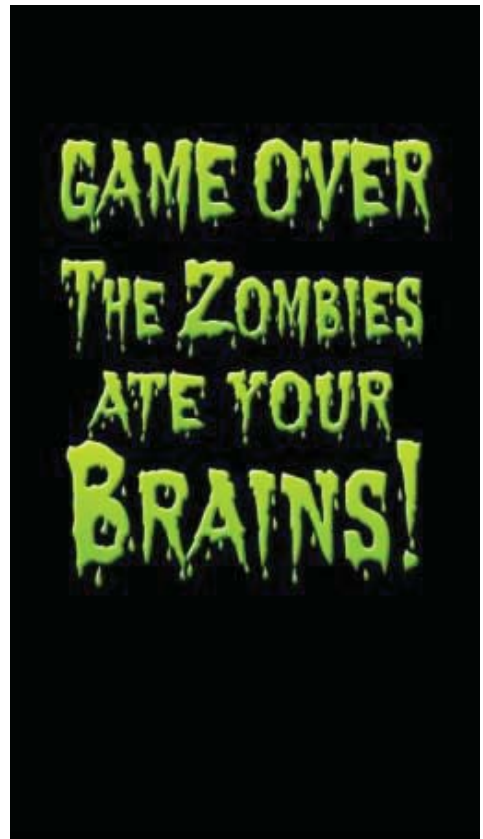

Regardless of the outcome the player will see how well they performed on the Results screen.

This details the score achieved, Zombies defeated and the tickets won.

Also the player has the chance to *upload their score on the Sega Scores website and see their ranking in the world.

www.segascores.com

*mobile phone/tablet with QR code reader and
 †data connection/Wi-Fi required.

¹charges may apply.



The last screen before returning to attract is the High Score Table.

This will show how well the player performed against other players.

Please note that the HST is specific to each cabinet and is not linked to the Sega Scores website.

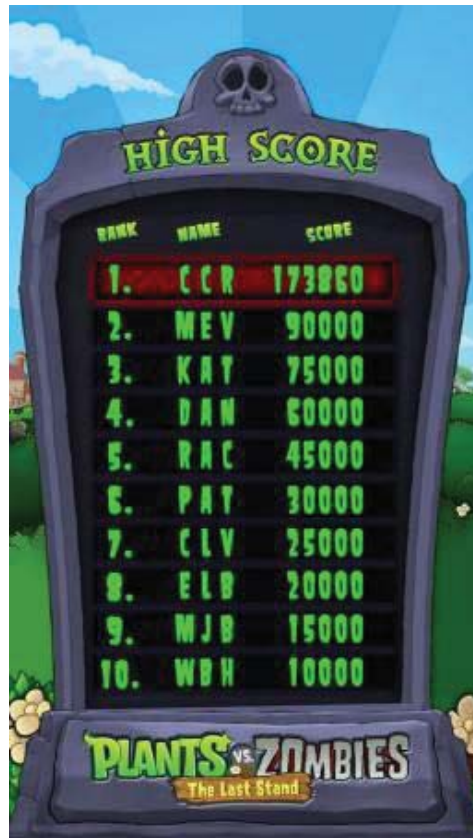

5

GAME DESCRIPTION AND SOFTWARE

6 TEST MODE

6-1 TEST MODE

TEST MENU

Press the TEST button to open the TEST MENU.

The following options are available from the Test Menu.

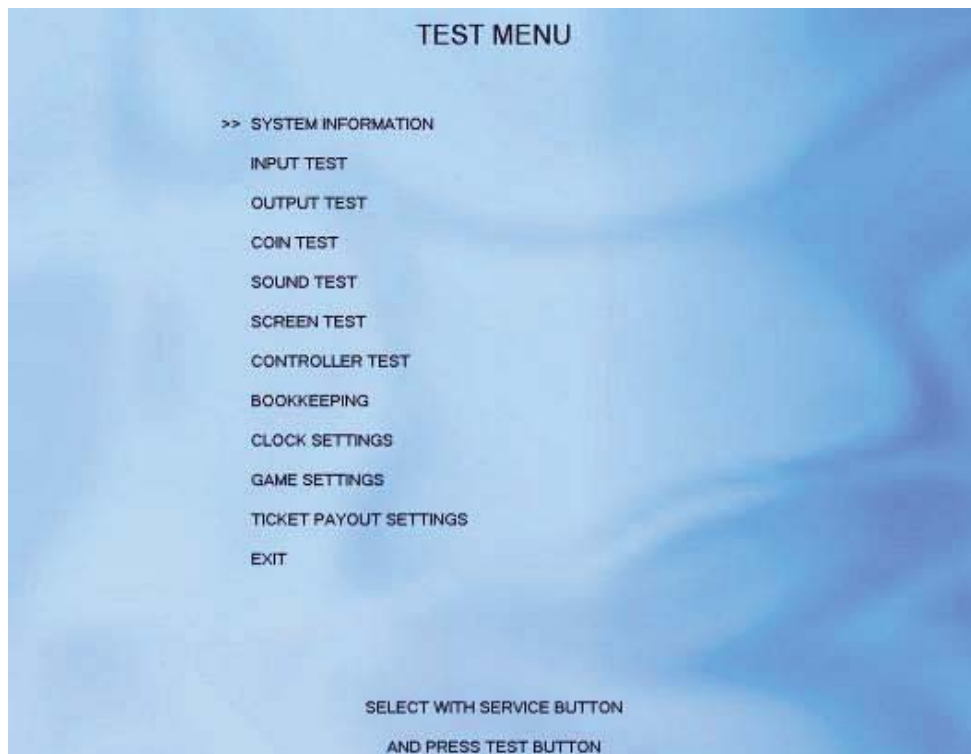

Use the SERVICE button to move the cursor to the desired test item.

Press the TEST button to enter the selected item.

SYSTEM INFORMATION	General Information on Software.
INPUT TEST	Test System Inputs such as the Coin entry and Ticket Notch
OUTPUT TEST	Test LED lighting and Ticket vending
COIN TEST	Coin and Service Credit counts and enable/disable FreePlay
SOUND TEST	Test speakers and adjust in game volume levels
SCREEN TEST	Test routine for the display screen.
CONTROLLER TEST	Calibrate and test Peashooter
BOOKKEEPING	View game types played and clear bookkeeping and high scores
CLOCK SETTING	Set System date and time settings
GAME SETTINGS	Change language options for game
TICKET PAYOUT SETTINGS	Change Ticket values and percentage payout levels
EXIT	Exit the Test Menu to return to the game

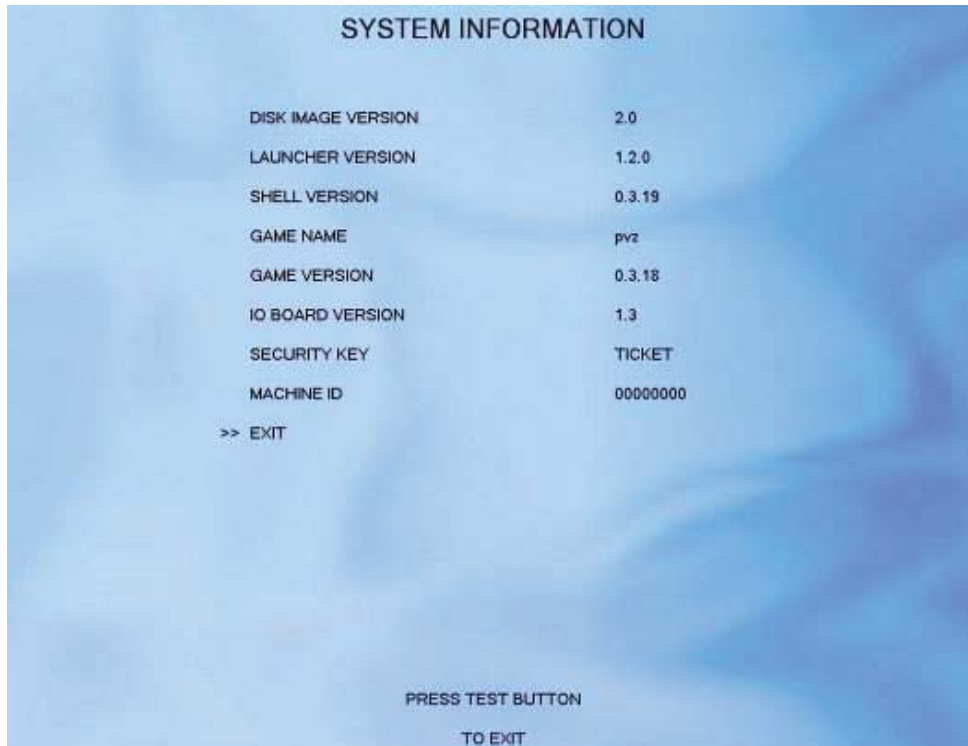
SYSTEM INFORMATION

Select 'System Information' from the Test Menu to display the System Information menu.

The System Information Test lists revision numbers and names of currently installed system components.

DISK IMAGE VERSION Version number for the master hard disk image

LAUNCHER VERSION Version number of System Launcher program

SHELL VERSION Version number of Shell program

GAME NAME Name of currently installed game

GAME VERSION Version number of currently installed game

IO BOARD VERSION Version number of IO board in use

SECURITY KEY Type of security key in use

MACHINE ID Unique number of the cabinet used to register on Sega Scores website (please visit www.segascores.com for instructions)

INPUT TEST

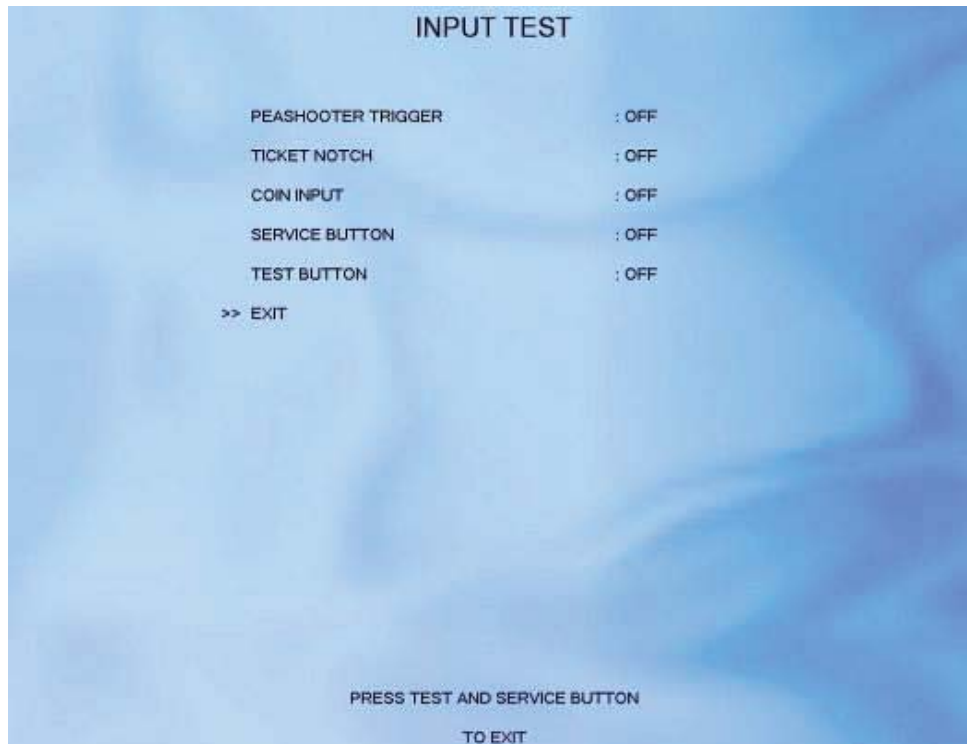

Select 'Input Test' from the Test Menu screen to display the Input Test menu.

This screen is used to test the system inputs such as the Peashooter triggers, ticket notch and coin input.

To implement the test, operate each device listed and check the results on screen. When activated and detected by the system the result on screen will be ON.

PEASHOOTER TRIGGER	Peashooter Triggers both left and right
TICKET NOTCH	Ticket notch opto sensor input from ticket vend unit
COIN INPUT	Coin pulse input
SERVICE BUTTON	Service button input
TEST BUTTON	Test button input

Press the TEST and SERVICE button simultaneously to exit INPUT TEST and return to the TEST MENU

OUTPUT TEST

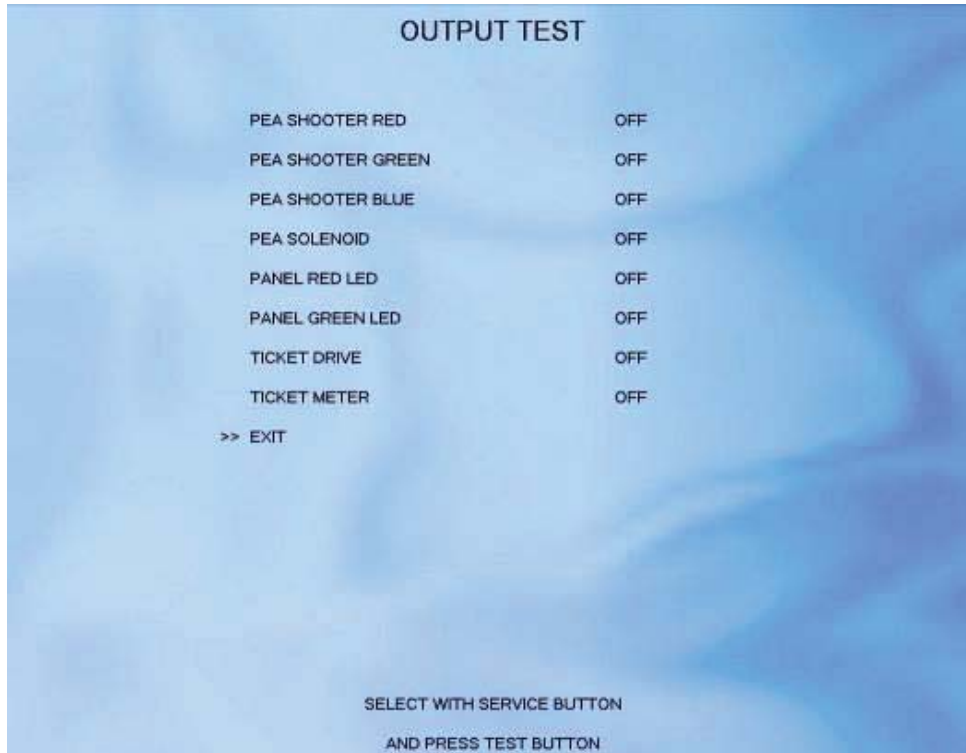

Select 'Output Test' from the Game Test Mode to display the Output Test Menu.

This test is used to check all configured outputs from the IO board.

Use the SERVICE button to move the cursor to the desired test item.

Press the TEST button to test the selected item.

PEASHOOTER RED	Change the colour of the Peashooter to RED
PEASHOOTER GREEN	Change the colour of the Peashooter to GREEN
PEASHOOTER BLUE	Change the colour of the Peashooter to BLUE
PEASHOOTER SOLENOID	Test the solenoid inside of the Peashooter
PANEL RED LED	Change optional lighting to RED
PANEL GREEN LED	Change optional lighting to RED
TICKET DRIVE	The ticket motor will dispense 1 ticket
TICKET METER	The ticket meter will increment by 1

Please note that turning on more than 1 Peashooter colour will change the colour of the Peashooter accordingly:

RED and GREEN	Panel will be YELLOW
RED and BLUE	Panel will be MAGENTA
GREEN and BLUE	Panel will be CYAN
RED, GREEN and BLUE	Panel will be WHITE

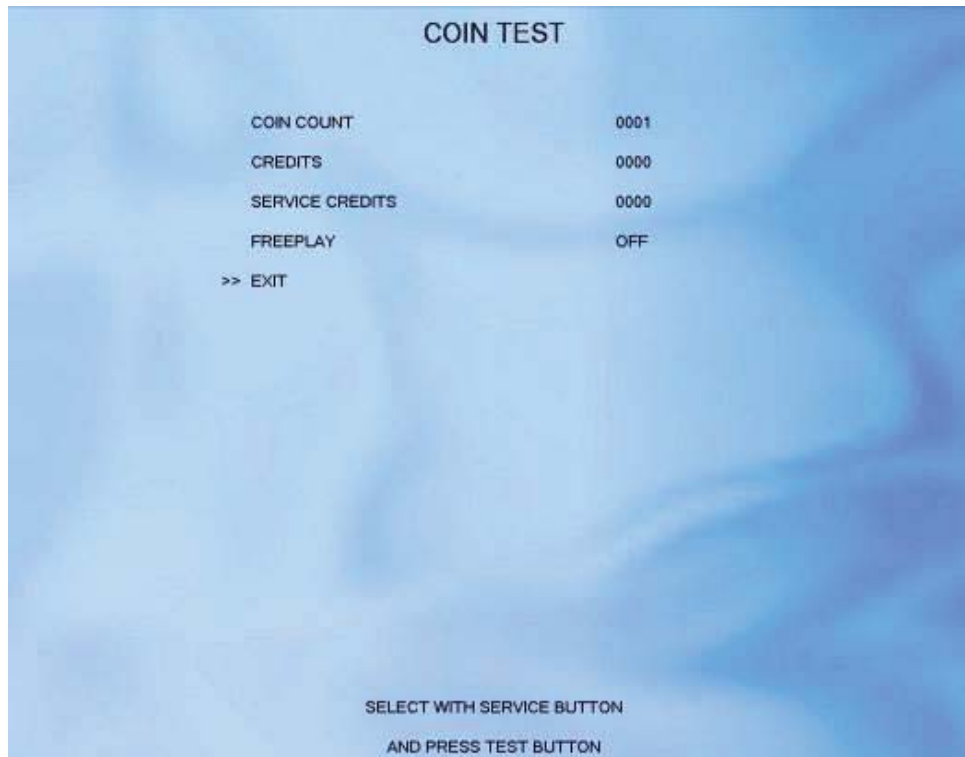
COIN TEST

Select 'COIN TEST' from the Test Menu screen to display the Coin Test screen.

COIN COUNT	Coin Count value from IO board (cannot reset)
CREDITS	Total number of Coin credits added to the system
SERVICE CREDITS	Total number of Service Credits added to the system
FREEPLAY	ON – Freeplay is on, pressing the Peashooter trigger during attract sequence will issue a credit. OFF – Credits can only be added using coins or service button.
EXIT	This will save any changes to Freeplay to this cabinet only

SOUND TEST

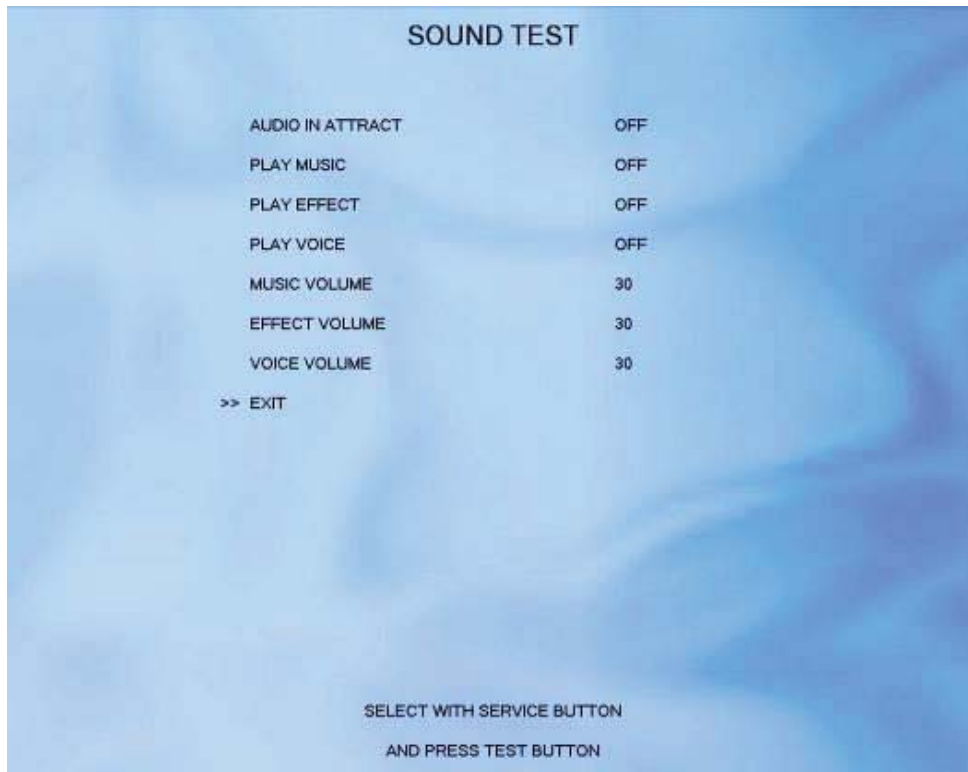

Select 'SOUND TEST' from the Test Mode to display the Sound Test screen.

This test is used to test the function of the speakers and set audio levels for the Game.

AUDIO IN ATTRACT	ON – sound will be played in Attract mode OFF – No sound in Attract mode
PLAY MUSIC	ON - Test the sound level of the music in game OFF – Turn the test music off
PLAY EFFECT	ON – Test the sound level of effects in game OFF – Turn the test music off
PLAY VOICE	ON – Test the sound level of voice in game OFF – Turn the test music off
MUSIC VOLUME	Change the volume of music in game 0-100 (increments of 5) Default value is 30
EFFECTS VOLUME	Change the volume of effects in game 0-100 (increments of 5) Default value is 30
VOICE VOLUME	Change the volume of voice in game 0-100 (increments of 5) Default value is 30
EXIT	This will save any changes to game volumes

SCREEN TEST

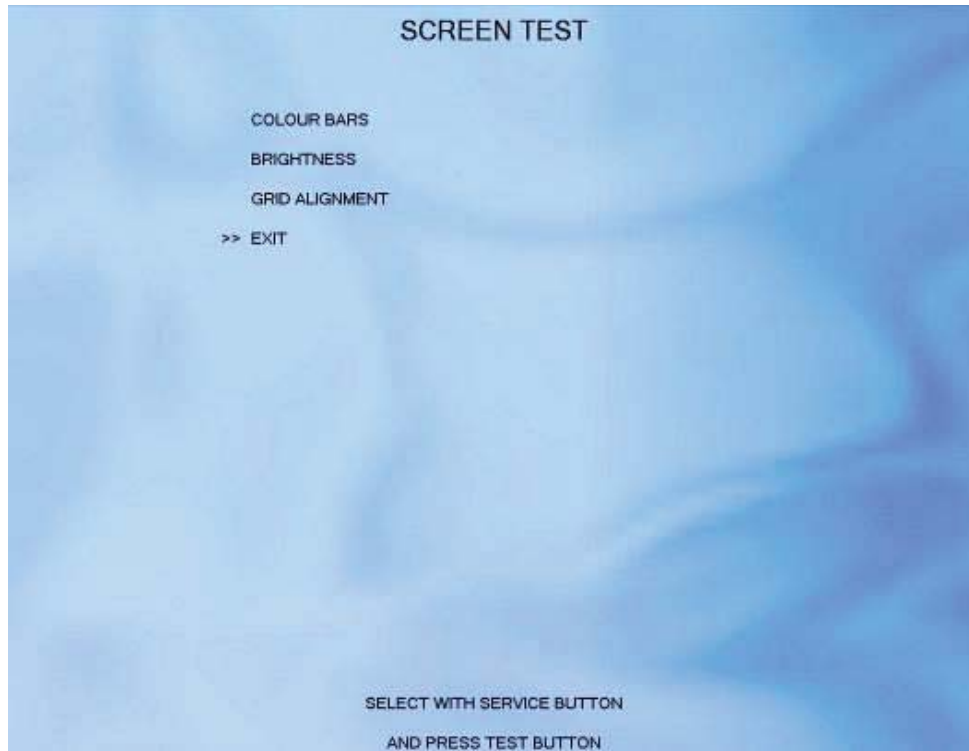

Select 'SCREEN TEST' from the Test Mode to display the Screen Test screen.

This test is used to display various test patterns for the display screen.

- COLOUR BARS** Displays vertical colour bars for colour balance correction
- BRIGHTNESS** Displays graduated greyscale for brightness adjustment
- GRID ALIGNMENT** Displays grid for screen size and alignment

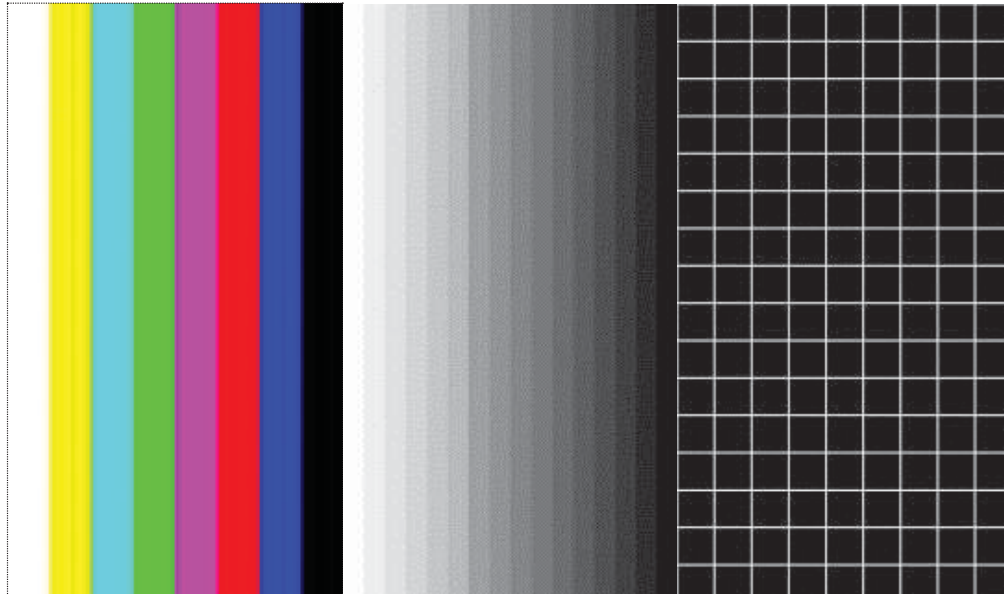

CONTROLLER TEST

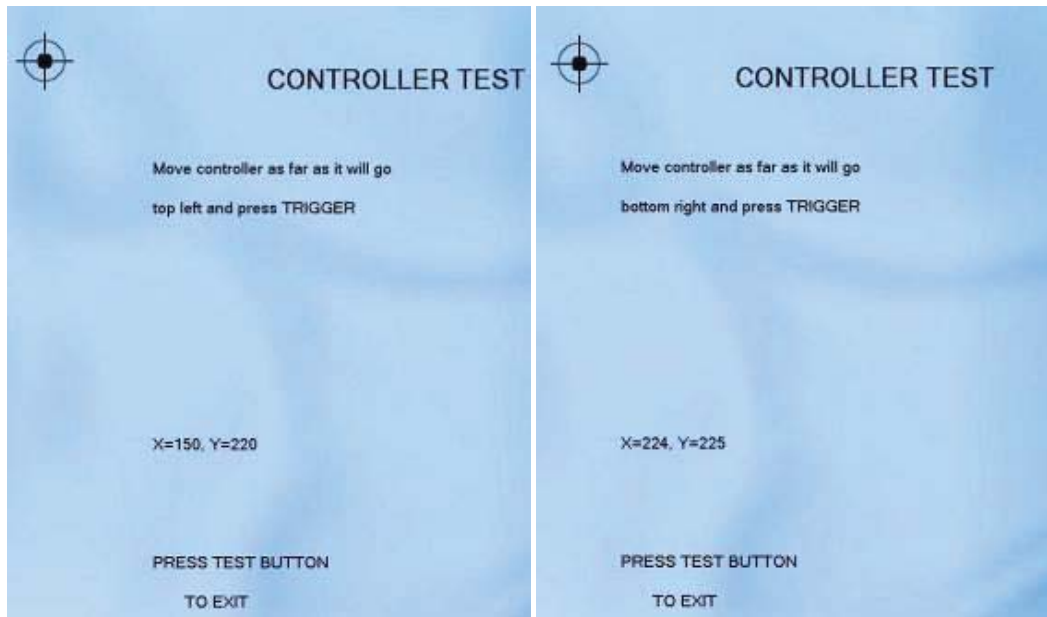

Select 'CONTROLLER TEST' from the Test Mode to display the Controller Test screen.

This test is used to calibrate the x and y coordinates of the Peashooter gun, this is to ensure reliable and accurate game play.

The calibration procedure requires you to MOVE the Peashooter gun as instructed on screen and then to press the TRIGGER. When completed you are able to move the Peashooter and see the cursor move around on the screen.

Press the Test button to exit.

BOOKKEEPING

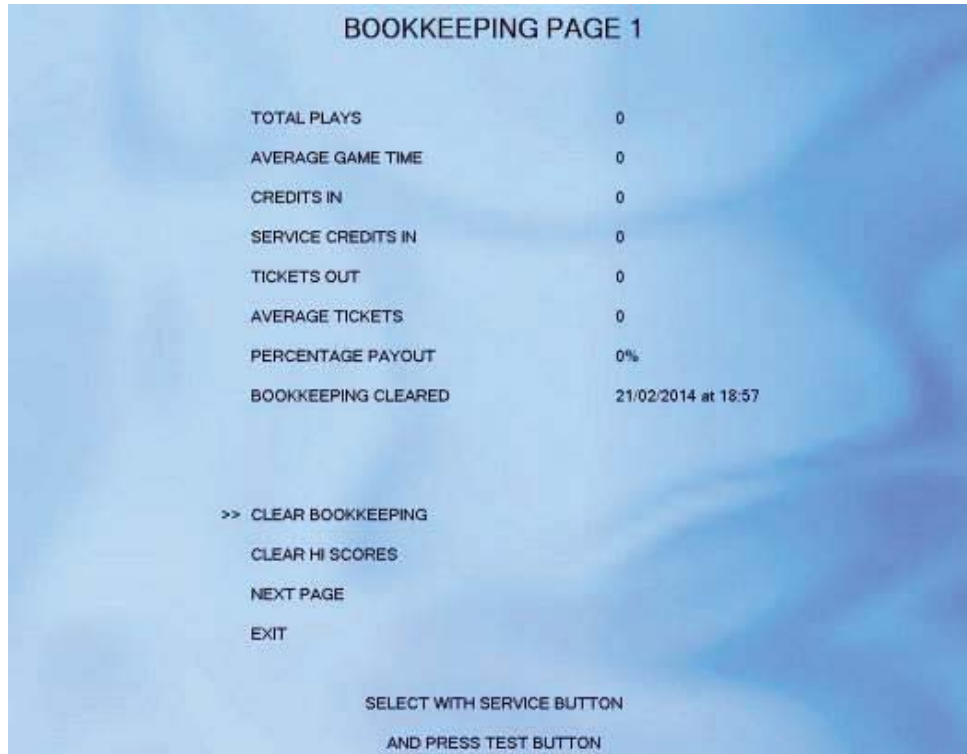

Select 'BOOKKEEPING' from the Test Mode to display the Bookkeeping Test screen.

This test is used to review statistical data from the system. It consists of 4 screens of data.

BOOKKEEPING PAGE 1

This page displays an overview of the coins and credits data.

TOTAL PLAYS	The total numbers of games played
AVERAGE GAME TIME	The average game time for all games
CREDITS IN	The total number of coin credits entered
SERVICE CREDITS IN	The total number of service credits entered
TICKETS OUT	The total number of tickets dispensed
AVERAGE TICKETS	The average number of tickets dispensed
PERCENTAGE PAYOUT	Current percentage payout
BOOKKEEPING LAST CLEARED	The date and time the Bookkeeping was last deleted

Use the SERVICE button to navigate, and the TEST button to action changes to the following options.

CLEAR BOOKKEEPING	Selecting this will delete ALL Bookkeeping data. WARNING – ONCE DELETED THIS INFORMATION CAN NOT BE RESTORED
--------------------------	---

CLEAR HI SCORES

Selecting this will delete ALL Hi Score data.
WARNING – ONCE DELETED THIS INFORMATION CAN NOT BE RESTORED

NEXT PAGE

This will take you to Page 2 of Bookkeeping

EXIT

Return to the main Test Menu screen.

BOOKKEEPING PAGE 2

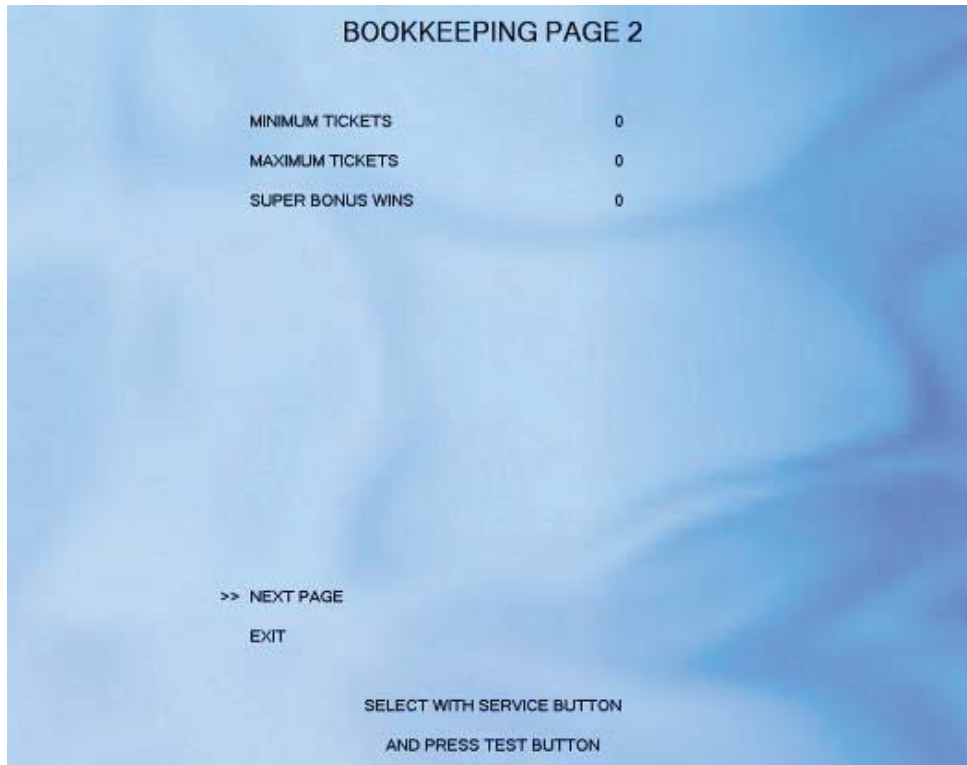

This page displays ticket pay out ranges and total Super Bonus wins.

MINIMUM TICKETS

Minimum tickets won in any game

MAXIMUM TICKETS

Maximum tickets won in any game excluding Super Bonus ticket values

SUPER BONUS WIN

Number of times Super Bonus has been won

Use the SERVICE button to navigate, and the TEST button to action changes to the following options.

NEXT PAGE

This will take you to Page 3 of Bookkeeping

EXIT

Return to the main Test Menu screen.

BOOKKEEPING PAGE 3

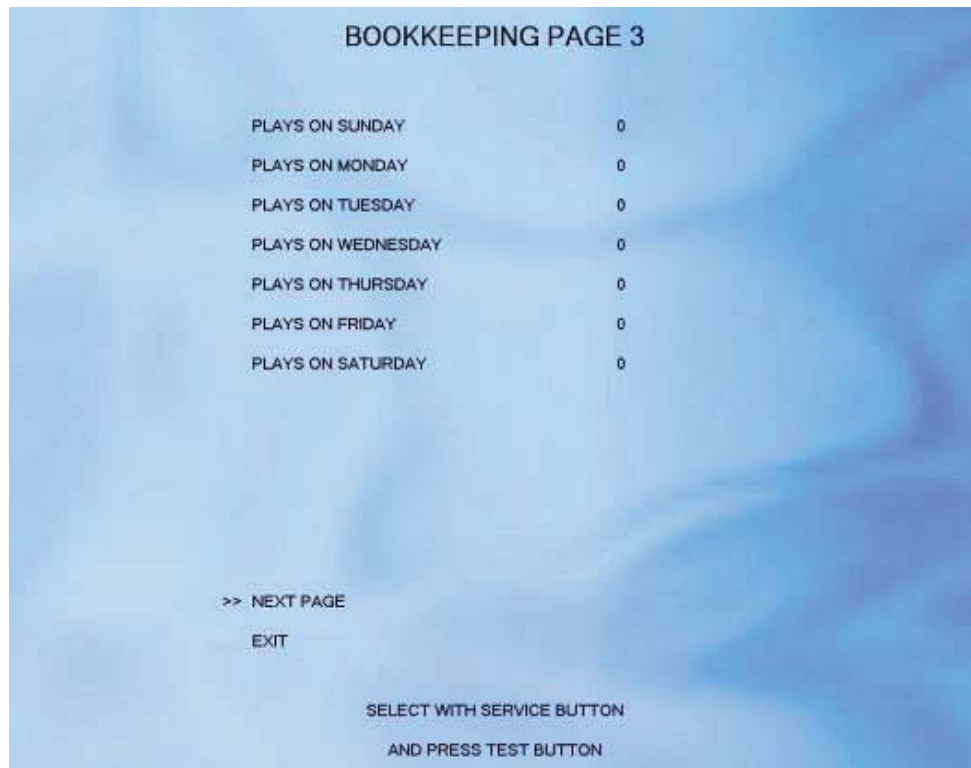

This page displays breakdown of the games on individual days. This is a cumulative total from the last point in time that the Bookkeeping was cleared.

PLAY ON SUNDAY	Total games played on a Sunday
PLAY ON MONDAY	Total games played on a Monday
PLAY ON TUESDAY	Total games played on a Tuesday
PLAY ON WEDNESDAY	Total games played on a Thursday
PLAY ON THURSDAY	Total games played on a Sunday
PLAY ON FRIDAY	Total games played on a Friday
PLAY ON SATURDAY	Total games played on a Saturday

Use the SERVICE button to navigate, and the TEST button to action changes to the following options.

NEXT PAGE	This will take you to Page 4 of Bookkeeping
EXIT	Return to the main Test Menu screen.

BOOKKEEPING PAGE 4

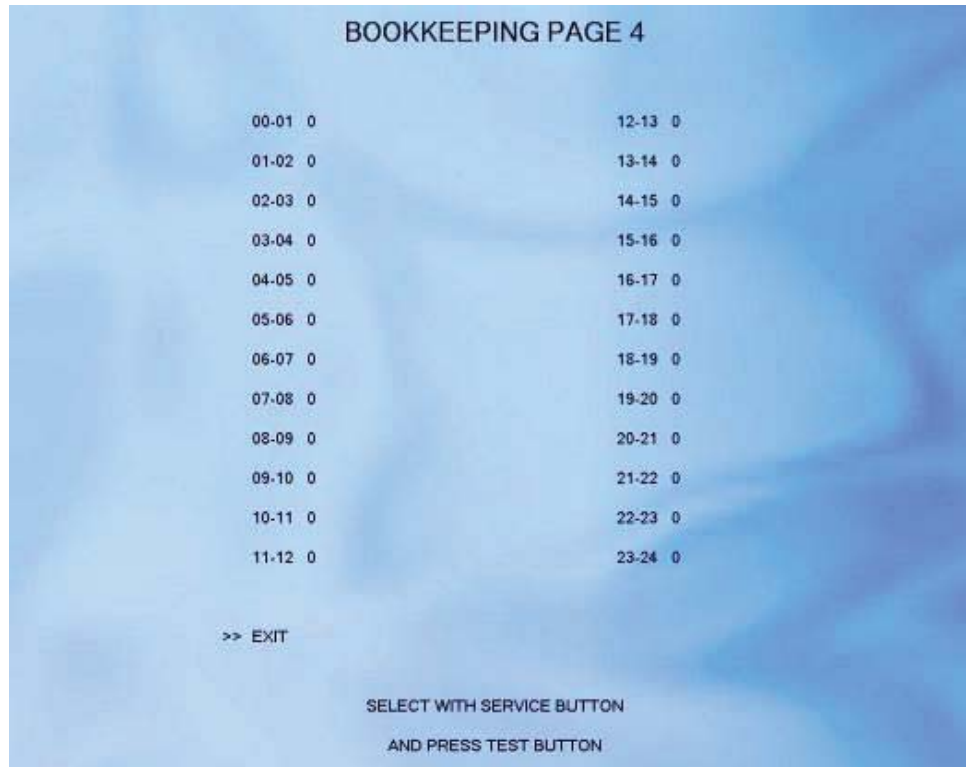

This page displays a breakdown of the games into hourly periods. This is a cumulative total from the last point in time that the Bookkeeping was cleared.

Each hour is logged separately in 24 hour format therefore

00-01 logs games between 12am and 1am

00-02 logs games between 1am and 2am.

and so on

23-24 logs games between 11pm and 12am.

Use the TEST button to exit.

EXIT Return to the main Test Menu screen.

CLOCK SETTING

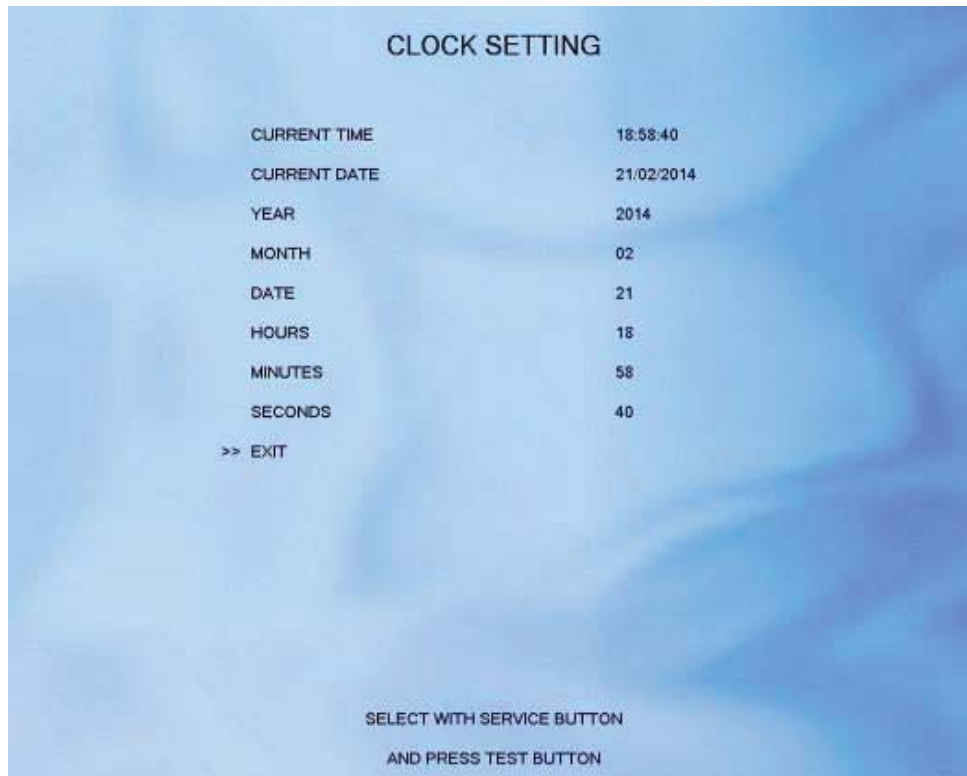

Select 'CLOCK SETTING' from the Test Menu screen to enter the Clock Setting screen.

This screen is used to set the time and date of the system.

CURRENT TIME Shows the current time. Displayed in 24 hour clock format HH:MM:SS
CURRENT DATE Shows the current date. Displayed in the following format DD/MM/YYYY

Use the SERVICE button to move the cursor to the desired item.
 Press the TEST button to test the selected item.

Use the service button to move the cursor to the item that needs to be changed and use the Test Button when that item is highlighted to change it to the desired setting. Changes made will automatically update CURRENT TIME and/or CURRENT DATE.

EXIT Press the Test button to return to the System Test Mode screen.

6-5 GAME SETTINGS

GAME SETTINGS

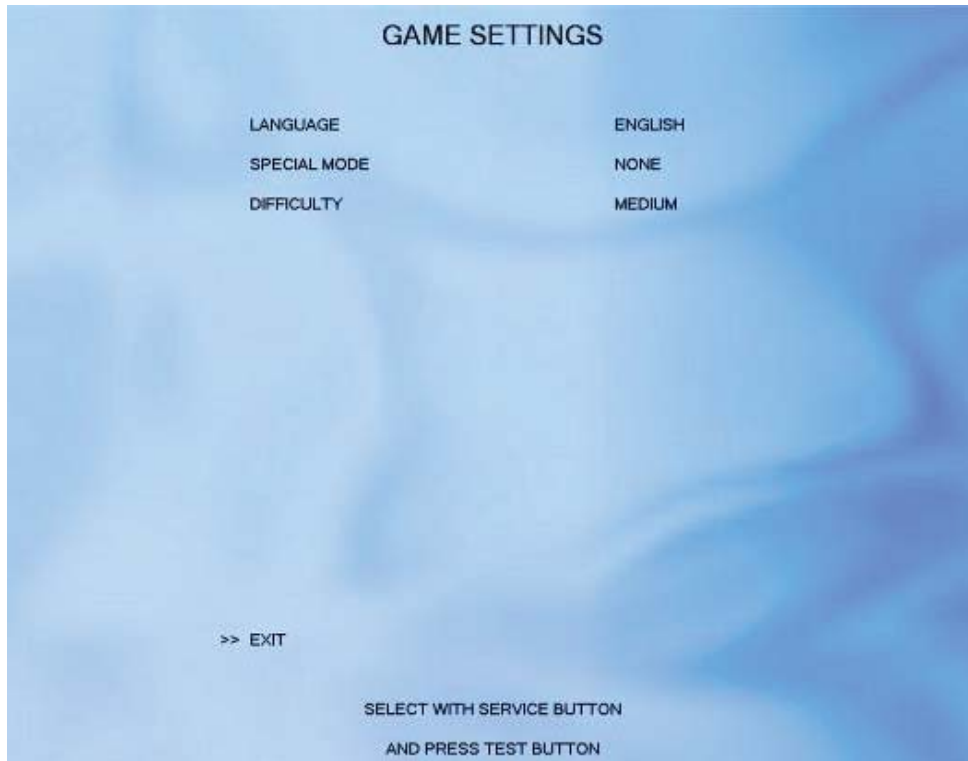

Select 'GAME SETTINGS' from the Test Menu screen to enter the Game Settings screen.

This test is used to change the language of the in game text, ticket payout type and difficulty.
NOTE TEST MENU text only displays in ENGLISH.

The following option is available from the Game Settings screen

LANGUAGE	Options available English, French, German, Spanish, Russian and Turkish
SPECIAL MODE	Options available None/2 for 1 Payout/ 6 Ticket Payout
DIFFICULTY	Options available Easy/Medium/Hard

6

TEST MODE

TICKET PAYOUT SETTINGS

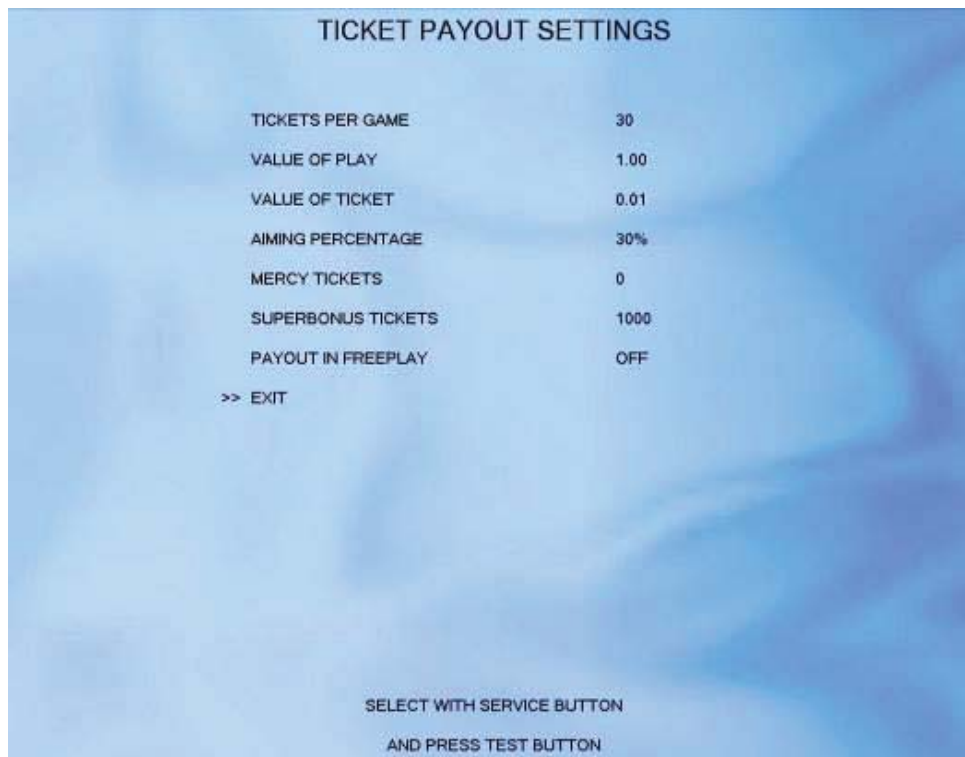

Select 'TICKET PAYOUT SETTINGS' from the Test Menu screen to enter the Ticket Payout Settings screen.

This test is used to change the percentage payout settings for the game, as well as enabling/disabling Mercy Tickets.

TICKETS PER GAME This value will automatically change based on the settings assigned below

The following options are available from the Game Settings screen

VALUE OF PLAY Price of Play to calculate percentage payout.
0.20, 0.25, 0.50, 1.00, 2.00

NOTE Credit board settings will also need to be configured

VALUE OF TICKET Set the financial value of 1 ticket
0.01, 0.02, 0.03, 0.04, 0.05, 0.06, 0.07, 0.08, 0.09, 0.10, 0.001, 0.002, 0.005

AIMING PERCENTAGE Set the desired percentage payout
20%, 25%, 30%, 35%, 40%, 45%, 50%, 55%, 60%, 65%, 70%, 75%, 80%

MERCY TICKETS Pay out Mercy tickets if NO tickets are won in a game. 0 (zero) is OFF
0, 1, 2, 3, 4, 5, 6, 7, 8, 9, 10

SUPERBONUS TICKETS Assign the value of the Super Bonus prize. Super Bonus payout is dependent on the percentage payout.

PAYOUT IN FREEPLAY 100, 200, 300, 400, 500, 600, 700, 800, 900, 1000
Turn ON/OFF the option to pay tickets out in Freeplay. Default setting is OFF

EXIT Exit Ticket Payout Settings saving the changes you have made.

7 CONTROLLER UNIT(S), SWITCHES AND BUTTONS

WARNING

- When working with the product, be sure to turn the power off. Working with the power on may cause an electric shock or short circuit.
- Be careful not to damage the wires. Damaged wires may cause an electric shock, short circuit or present a risk of fire.
- Exercise due caution in performing soldering work. If soldering iron is handled carelessly, there could be fires or burns.

CAUTION

- When fastening plastic parts, be careful not to tighten screws or nuts excessively. If these are tightened to excess, parts could be damaged, resulting in injuries from fragments, etc.
- After the unit has been disassembled and reassembled again, check carefully that the unit has been reassembled correctly.
- Be sure to inspect the outer covers on both gear and hand brake units.
- Assemble so that there is no gap between the L and R covers. If there is a gap or rattling, the players could get fingers or hands caught, resulting in injury.

IMPORTANT

- Once the product has been disassembled, use slack preventive agent (product No. : 090-0012-N). Coat screws with suitable amounts of this agent and then tighten them. If this agent is not used, the product might start rattling or come apart.
- Use the slack preventive agent prescribed in these instructions. If any other agent is used, there could be chemical changes that inhibit the use of screws and part surfaces could be damaged.
- Be careful not to damage or lose small parts or screws.
- When a part has been replaced, be sure to always make adjustments and check conditions in Test Mode.

7-1 REMOVING THE CONTROLLER

STOP IMPORTANT

Be sure to disconnect the power from the machine before performing any work. Failure to remove the power may result in electric shock or component damage.

- 1 Turn off the power. Remove the 2x screws from the small finger trap plate located at the front of the Gun base. Remove plate.

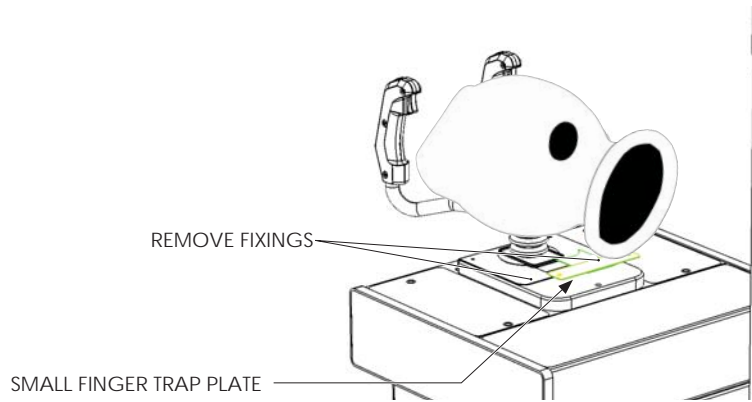

- 2 Remove the 2 screws from the finger trap plate located at the rear base of the controller. Remove plate.

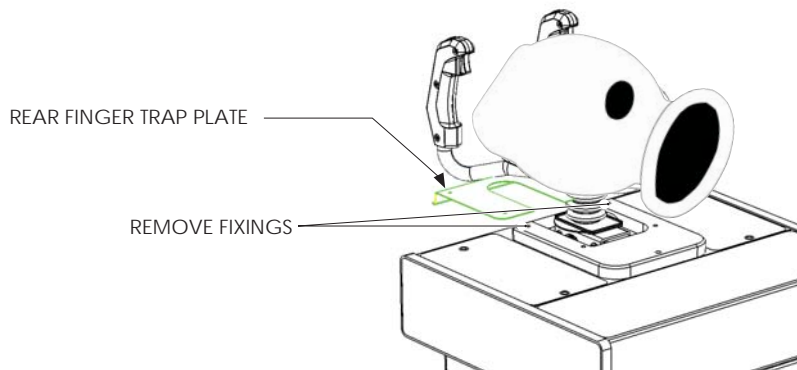

- 3** Remove the 4 screws which secure the Control Panel to the cabinet.

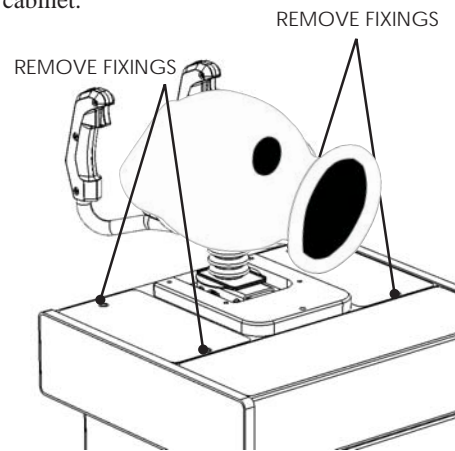

- 4** Carefully slide out the Controller Base and Control Panel in opposite directions as illustrated.

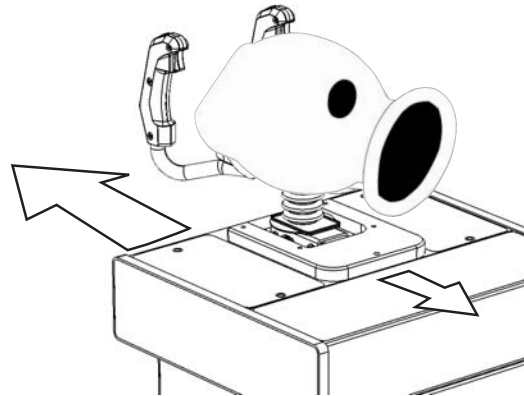

- 5** Remove the 4x M8 Hex Bolts located at the base of the Controller. Take care in disconnecting the Controller Harness and remove the controller.

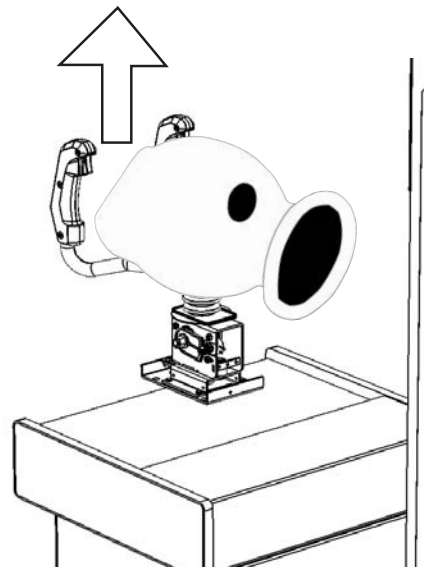

STOP

IMPORTANT

Be sure to perform volume's move value setting in the INPUT ASSIGNMENTS in the Game Test Mode after replacing or adjusting the Volume.

7-2 ADJUSTING/REPLACING THE VOLUME POT

ADJUSTMENT PROCEDURE

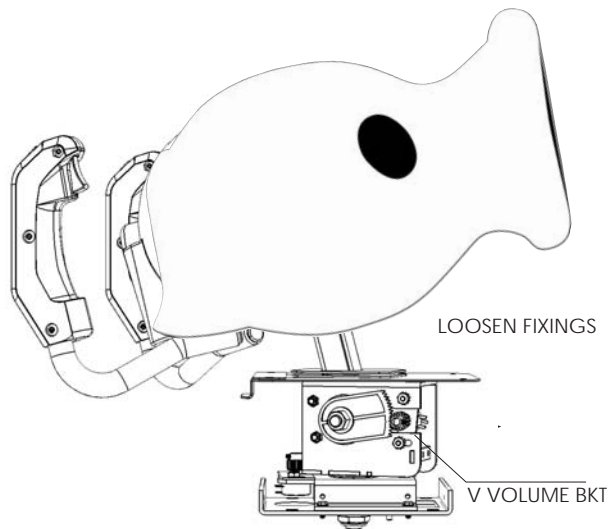

- 1** Apply this procedure to both Horizontal and Vertical Volume Pots. Loosen the 2 screws that secure the VR Bracket and move the VR Bracket to adjust the angle and condition of the gear alignment.
- 2** Locate the central position of the pot by turning the pot in both clockwise and counterclockwise positions. Once a central position of the pot has been determined, straighten the handle so that the gear is positioned horizontally. Slide the pot into position engaging the gears.
- 3** Tighten the 2 screws and secure the VR Bracket and refit the cover.
- 4** Check to make sure the value on the Input Test screen is within the range $80H \pm 8H$ when the steering unit is in the straight position.

REPLACEMENT PROCEDURE

This procedure requires the following tools: Phillips screwdriver for the M4 screws, 1.5 mm hexagonal wrench, 11-12 mm monkey wrench, nipper, cutter, wire stripper, soldering iron, industrial dryer and heat-shrinkable tube.

- 1 Remove the connectors.
- 2 Remove the 2 screws securing the VR Bracket and remove the entire Bracket and V.R. (See previous instruction)
- 3 Loosen the 1 hexagon socket screws on the Gear Holder and remove the Gear Holder.
- 4 Remove the nut securing the VR Bracket, then separate the Volume from the VR Bracket and replace it.
- 5 Check to make sure the value on the Input Test screen is within the range $80H \pm 8H$ when the steering unit is in the straight position.

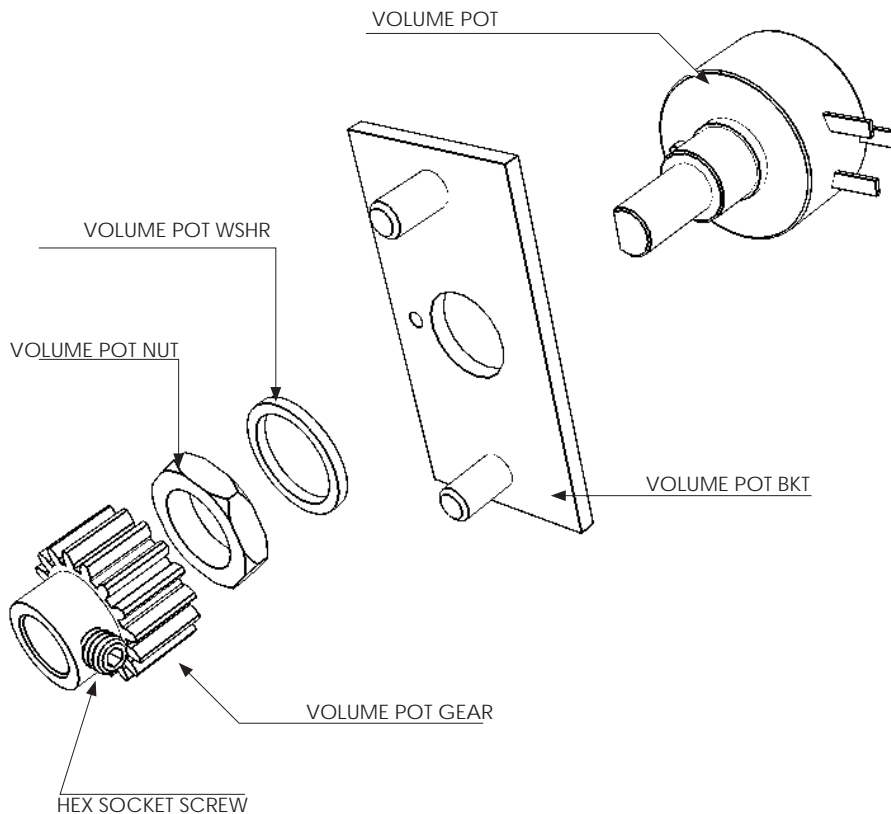

6 The wire connected to the volume pot will be reused. Use a tool such as a pair of snips or cutters to remove the old heatshrink tubes which cover the contacts.

7 Use a soldering iron to melt the solder and separated the wires from the old volume pot. Be very careful when using a soldering iron.

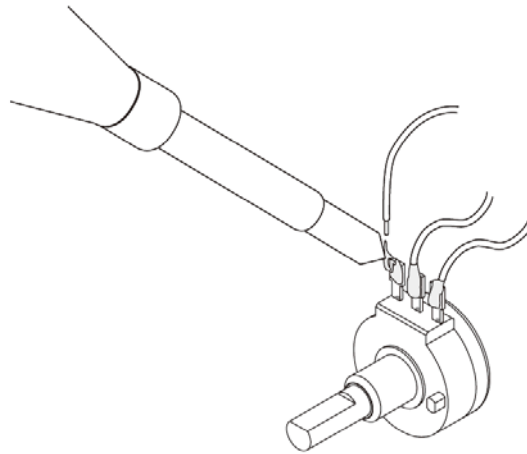

8 If the exposed conductive wire at the end is less than 5mm, use a tool such as a wire stripper or cutter to cut the wire insulation back to a workable length. Place new sleeving over the wire before resoldering them to the pot.

9 Once soldered, cover the bare contacts with the sleeving. If heatshrink is used, apply heat from an appropriate hot air blower to shrink the sleeving tightly over the contacts.

10 Reassemble the pot to the pot bracket by working in reverse order of these instructions. Refer to the POT VOLUME ADJUSTMENT section of this manual.

7-3 GREASING

STOP IMPORTANT

- Be sure to use the designated grease. Using undesignated grease can cause parts damage.
- Do not apply grease to locations other than as specified. Doing so may create a risk of operational problems and deterioration of parts.
- The designated periods for greasing serve only as a guide. Whenever there are squeaks or other anomalies, apply grease at designated locations.

Use spray grease once every three months to grease up the gear mesh portion of the constituent parts.
Use "Grease Mate" (part number 090-0066) for the spray grease.

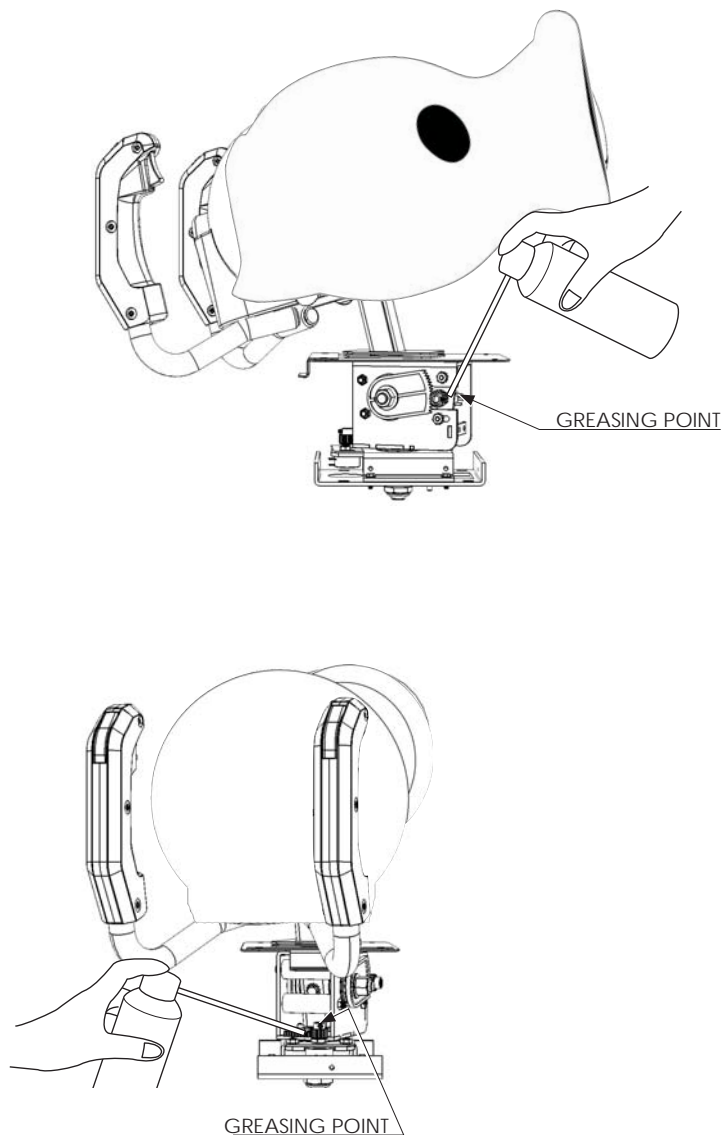

8 LCD DISPLAY (VGA)

8-1 SAFETY PRECAUTIONS WHEN HANDLING THE MONITOR

WARNING

Responding to breakdown or abnormality

- If smoke or a strange odor appears, immediately unplug the power cable from the power source.

Continuing to use the product may cause a fire or an electric shock. Ensure that smoke is no longer emitted, and contact the point of purchase.

- If nothing displays on the screen, immediately unplug the power cable from the power source.

Continuing to use the product may cause a fire or an electric shock. Contact the point of purchase and request an inspection.

- If water or a foreign object enters the monitor's interior, immediately unplug the power cable from the power source.

Continuing to use the product may cause a fire or an electric shock. Contact the point of purchase and request an inspection.

- If the monitor is dropped or the cabinet is damaged, immediately unplug the power cable from the power source.

Continuing to use the product may cause a fire or an electric shock. Contact the point of purchase and request an inspection.

During operation

- Do not repair, reconstruct, or disassemble the monitor.

The monitor's interior contains high voltage parts. A fire or an electric shock could result.

For inspections, adjustments, and repair of the monitor's interior, request work from the point of purchase.

- Do not insert foreign objects.

If metal objects or flammable materials such as paper are inserted into the interior through ventilation openings or other apertures, an electric shock could result.

- In the event of a thunder storm, do not touch the product or the power cable. An electric shock could result.

- Make sure to perform appropriate adjustments. Do not operate the product when the screen is flickering, distorted, or experiencing other abnormalities. Images from an improperly adjusted screen could cause players and other customers to experience dizziness, headaches, and other ailments.

8-2 CLEANING THE SCREEN SURFACE

CAUTION

- Use a soft, dry cloth (**flannel-type**) to wipe away dirt. Do not use materials such as coarse mesh gauze.
- Alcohol (ethanol) is the recommended solvent for removing dirt. When using a cleaning agent, follow the precautions below.
 - Dilute neutral cleaning agents for home use with water. Soak a soft cloth in the solution, and wring it thoroughly before wiping the screen.
 - Do not use abrasive cleaning agents or powders, or cleaning agents containing bleach.
 - Do not use alkaline cleaning agents such as glass cleaners, or solvents such as thinners.
- Do not scrub or scratch the screen surface with abrasive materials such as brushes or scrub brushes.

CLEAN THE SCREEN DAILY.

9 COIN HANDLING

Handling the Coin Jam

If the coin is not rejected when the REJECT button is pressed, open the coin chute door and open the selector gate. After removing the jammed coin, put a normal coin in and check to see that the selector correctly functions.

9-1 CLEANING THE COIN SELECTOR

STOP IMPORTANT

- Remove and clean smears by using a soft cloth dipped in water or diluted chemical detergent and then squeezed dry.
- Never apply machine oil, etc. to the Coin Selector.
- After cleaning the Coin Selector, insert a regular coin in the normal working status and ensure that the selector correctly functions.

The Coin Selector should be cleaned once every 3 months.
When cleaning, follow the procedure below:

- 1 Turn the power for the machine OFF. Open the Coin Chute Door
- 2 Remove the Coin Selector from the Coin Chute Door
- 3 Open the gate and dust off by using a soft brush (Small soft Paint Brush, etc.)

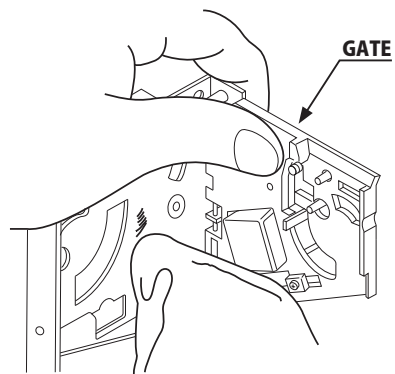

9-1 FIG 1

CLEANING THE COIN SELECTOR (MECHANICAL).

1 Remove and clean smears by using a soft cloth dipped in water or diluted chemical detergent and then squeezed dry.

2 Remove the CRADLE.. When removing the retaining ring (E ring) be very careful so as not to bend the rotary shaft.

3 Remove stain from the rotary shaft and shaft receiving portions by wiping off with a soft cloth. etc.

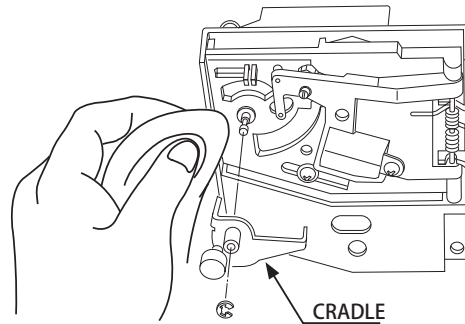

9-1 FIG 2

4 After wiping off as per previous step, further apply a dry cloth to completely dry the Coin Selector.

Coin Insertion Test

Once every month, when performing the Coin SW Test, simultaneously check the following:

Does the Coin Meter count satisfactorily?

Does the coin drop into the cashbox correctly?

Is the coin rejected when inserted while keeping the REJECT Button pressed down?

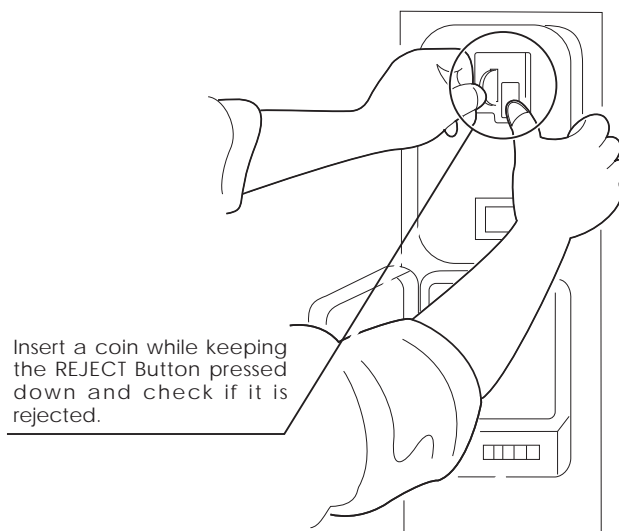

9-1 FIG 3

CLEANING THE COIN SELECTOR (SR3) <continued>

- 1** Remove and clean smears by using a damp soft cloth dipped in water. **DO NOT** use any diluted chemical detergent or cleansing agent as this will impair the workings of the component.

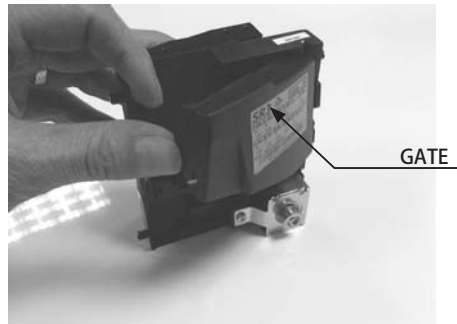

- 2** Open the reject gate to gain access to the rundown path.

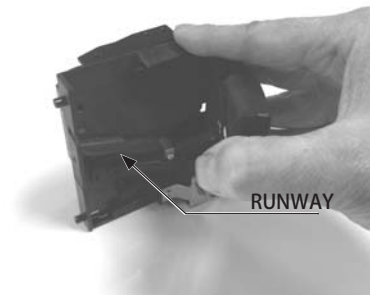

- 3** Remove the dirt and stains from the runway by wiping off with a soft damp cloth.

- 4** After wiping off as per previous step, further apply a dry cloth to completely dry the coin Selector.



9-2 FAULT FINDING

Fault Finding

The following information is presented for customers' guidance in rectifying a fault but does not cover all possible causes.

All acceptors with electronic faults should be returned to an approved service centre for repair.

SYMPTOM	INVESTIGATE	POSSIBLE CAUSE
Acceptor does not work (all coins reject)	Connector	Poor Contact
		Loose Wire
	Power Supply	Not switched on
		Incorrect voltage
		Inadequate current
		Rise time too slow
	Inhibit all inputs	Acceptor Inhibited
	Accept gate	Gate not free or dislocated
	Accept channel	Obstruction
	Reject gate	Not fully closed
	LED on rear cover RED	EEPROM chksm error
SR Sensor fault		
Credit opto fault		
Credit sensor blocked		
Reject lever pressed		
LED on rear cover YELLOW	Reinstall power	
Poor Acceptance	Power Supply	Voltage less than 10v (Voltage drops when coil engages)
	Accept gate	Gate jam or dislocated
	Connector	Loose
	Coin rundown	Dirty
Bank Select	Both banks enabled	
Coin stick or jam in acceptor.	Accept channel	Acceptor dirty or may have some damage
	Accept gate	
	Reject gate	
A true coin type rejects	Label	Coin not programmed
No accept signal	Connector	Loose or broken wire
	Accept channel	Path dirty or obstructed

10 PERIODIC INSPECTION

The items listed below require periodic check and maintenance to retain the performance of this machine and to ensure safe business operation.

When handling the controller, the player will be in direct contact with it. In order to always allow the player to enjoy the game, be sure to clean it regularly. Also, it is advisable to provide wet tissue, etc. available for player use.

WARNING

- Every 6 months check to see if power cords are damaged, the plug is securely inserted, dust is accumulated between the socket outlet and the power plug, etc. Using the product with accumulated dust in the interior may cause fire or electric shock.
- Never use a water jet, etc. to clean the inside and outside of the cabinet. If wetness occurs for any reason, do not use the product until it has completely dried.
- Once a year, request the office shown on this manual or the dealer from whom the product was originally purchased to perform the internal cleaning. Using the product with accumulated dust in the interior may cause fire or other accidents.

Note that you are liable for the cost of cleaning the interior parts.

- There is the danger of accidents involving electrical shorts circuits or fire caused by factors such as the deterioration of insulation in electrical and electronic equipment over time. Check that there are no abnormalities such as odors from burning.

14 TABLE 01 PERIODIC INSPECTION TABLE

ITEMS	DESCRIPTION	PERIOD
CABINET	Confirm that adjusters contact floor	Daily
CONTROL PANEL CONTROLLER	H and V POT inspection	Monthly
	Gear alignment inspection	Every 3 months
	Greasing	Every 3 months
MONITOR	Screen cleaning	Weekly
	Confirm settings	Monthly or when moving
COIN CHUTE DOOR	Coin switch inspection	Monthly
	Coin insertion test	Monthly
	Selector cleaning	Every 3 months
GAME BOARD	Confirm settings	Monthly
POWER CABLES	Inspection, Cleaning	6 months
INTERIOR	Cleaning	Yearly
CABINET SURFACES	Cleaning	As appropriate
LAMPS/LEDS	Check Operation	As appropriate

Cleaning the Cabinet Surfaces

When the cabinet surfaces are badly soiled, remove stains with a soft cloth dipped in water or diluted (with water) chemical detergent and squeezed dry. To avoid damaging surface finish, do not use such solvents as thinner, benzine, etc. other than ethyl alcohol, or abrasives, bleaching agent and chemical dustcloth. Some general-purpose household, kitchen and furniture cleaning products may contain strong solvents that degrade plastic components, coatings, and print. Before using any cleaning product, read the product's cautionary notes carefully and test the product first on a small area that is not highly visible.

Controller (Greasing to H and V Potentiometers)

Apply a suitable lubricant to the gearing of the potentiometers. Please visit Chapter 7 of this manual for complete disassemble and assemble instructions.

11 GAME BOARD

11

GAME BOARD

WARNING

- When working with the product, be sure to turn the power off. Working with the power on may cause an electric shock or short circuit.
- Be careful not to damage the wires. Damaged wires may cause an electric shock, short circuit or present a risk of fire.
- Do not use this product with connectors other than those that were connected and used with the game board at the time of shipping. Do not carelessly connect wires to connectors that were not used at the time of shipping, as this may cause overheating, smoke or fire damage.

CAUTION

In this product, setting changes are made during the test mode. The game board need not be operated. Use the game board, etc. as is with the same setting made at the time of shipment so as not to cause electrical damage or malfunction.

IMPORTANT

Static electricity from your body may damage some electronics devices on the IC board. Before handling the IC board, touch a grounded metallic surface so that the static electricity can be discharged.

11-1 GAME BOARD - LOCATION & REMOVAL

⚠ WARNING

- When returning the game board after making repairs or replacements, make sure that there are no errors in the connection of connectors. Erroneous connections can lead to electrical shock, short circuits or fires.
- When connecting a connector, check the direction carefully. Connectors must be connected in only one direction. If indiscriminate loads are applied in making connections, the connector or its terminal fixtures could be damaged, resulting in electrical shock, short circuits or fires.

The machine is fitted with Game Board Unit and several other Ancillary Boards which are fitted inside the Display Cabinet. Each machine contains the its own CPU.. Only qualified Personnel should attempt to Service these Units and before gaining access to the machine, it should be isolated from the mains supply

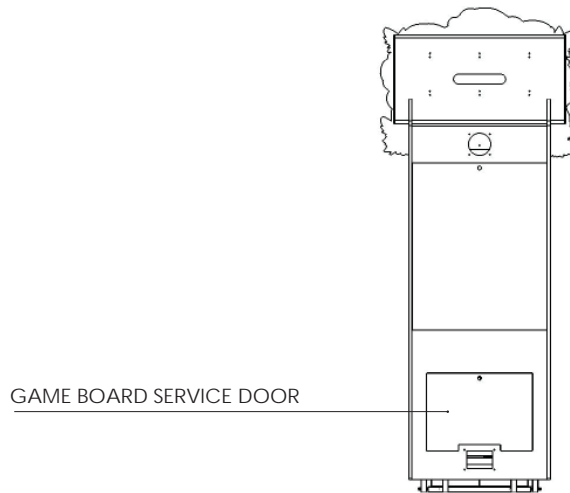

There is only one access point to the GAME BD which is through the GAME BD SERVICE DOOR located at the rear of the cabinet. Unlock the GAME BD SERVICE DOOR, the GAME BD is located on the inside left hand wall of the cabinet.

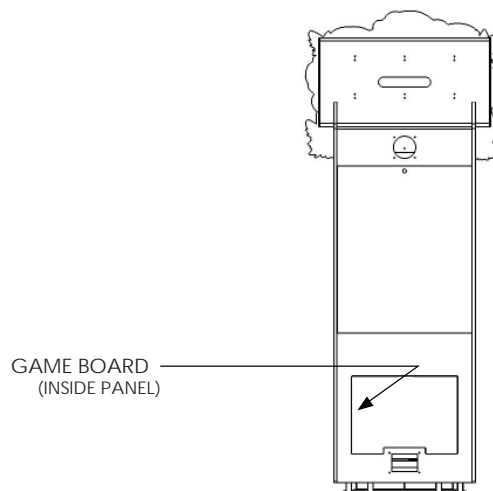

The GAME BD is mounted on a wooden Base. To remove the GAME BD, disconnect ALL connections to the GAME BD, unscrew the single fixing which secures the wooden base to the cabinet and carefully slide out the ASSY GAME BD from within the cabinet.

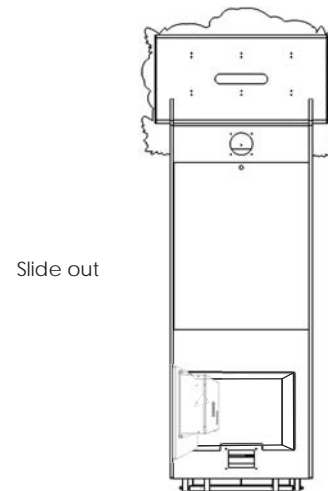
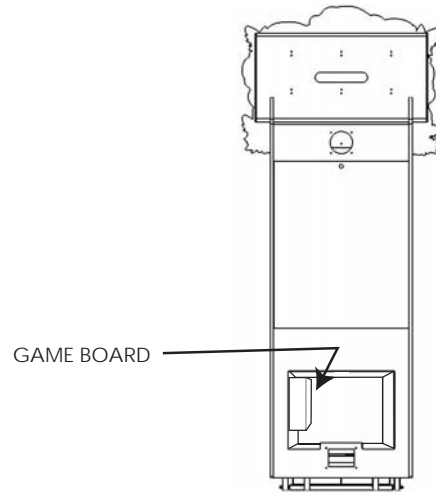

CONNECTIONS

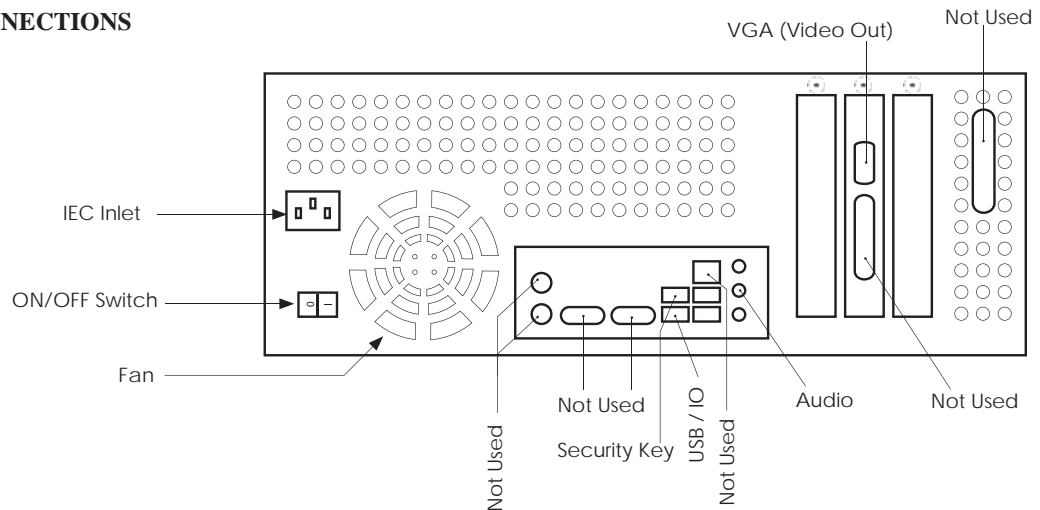

12 DESIGN-RELATED PARTS

For the warning display stickers, refer to Section 1.

12

DESIGN - RELATED PARTS



Part	Part #	Part Name
1	PV-0502	Billboard Rear
2	PV-0503	Billboard Name Plate
3	PV-0504	Billboard Sub Name Plate
4	PV-1063	Monitor Cabinet Left
5	PV-1064	Monitor Cabinet Right
6	PV-1065	Sticker Gun Cabinet Left
7	PV-1066	Sticker Gun Cabinet Right
8	PV-1074-A	Sticker Gun Rear(How to Play)
9	PV-1074-B	Sticker Gun Left(Crazy Dave)
10	PV-1074-C	Sticker Gun Right(Zombie)
11	PV-1075-A	Sticker Lower Front Left
12	PV-1075-B	Sticker Lower Front Right
13	PV-2003	Sticker Peashooter Eye
14	PV-2007	Sticker Peashooter End
15	PV-3001	Light Panel Tombstone
16	PV-3501	Light Panel Keep Off the Grass
17	PV-5005	Screen Protector Glass
	PV-1075-C	Sticker lower front prize(not pictured)

13 PARTS LIST



FIGURE 1

13

PARTS LIST

FIGURE 1

13

PARTS LIST

Part	Part #	Part Name
1	PV-0502	Billboard Rear
2	PV-0503	Billboard Name Plate
3	PV-0504	Billboard Sub Name Plate
4	PV-1063	Monitor Cabinet Left
5	PV-1064	Monitor Cabinet Right
6	PV-1065	Sticker Gun Cabinet Left
7	PV-1066	Sticker Gun Cabinet Right
8	PV-1074-A	Sticker Gun Rear(How to Play)
9	PV-1074-B	Sticker Gun Left(Crazy Dave)
10	PV-1074-C	Sticker Gun Right(Zombie)
11	PV-1075-A	Sticker Lower Front Left
12	PV-1075-B	Sticker Lower Front Right
13	PV-2003	Sticker Peashooter Eye
14	PV-2007	Sticker Peashooter End
15	PV-3001	Light Panel Tombstone
16	PV-3501	Light Panel Keep Off the Grass
17	PV-5005	Screen Protector Glass
18	PV-1075-C	Sticker lower front prize(not pictured)
19	PV-2004-UK	Gun Body
20	PV-5100-UK	Sunflower Seat

PARTS LIST cont.

Gun Mech parts

FIGURE 2

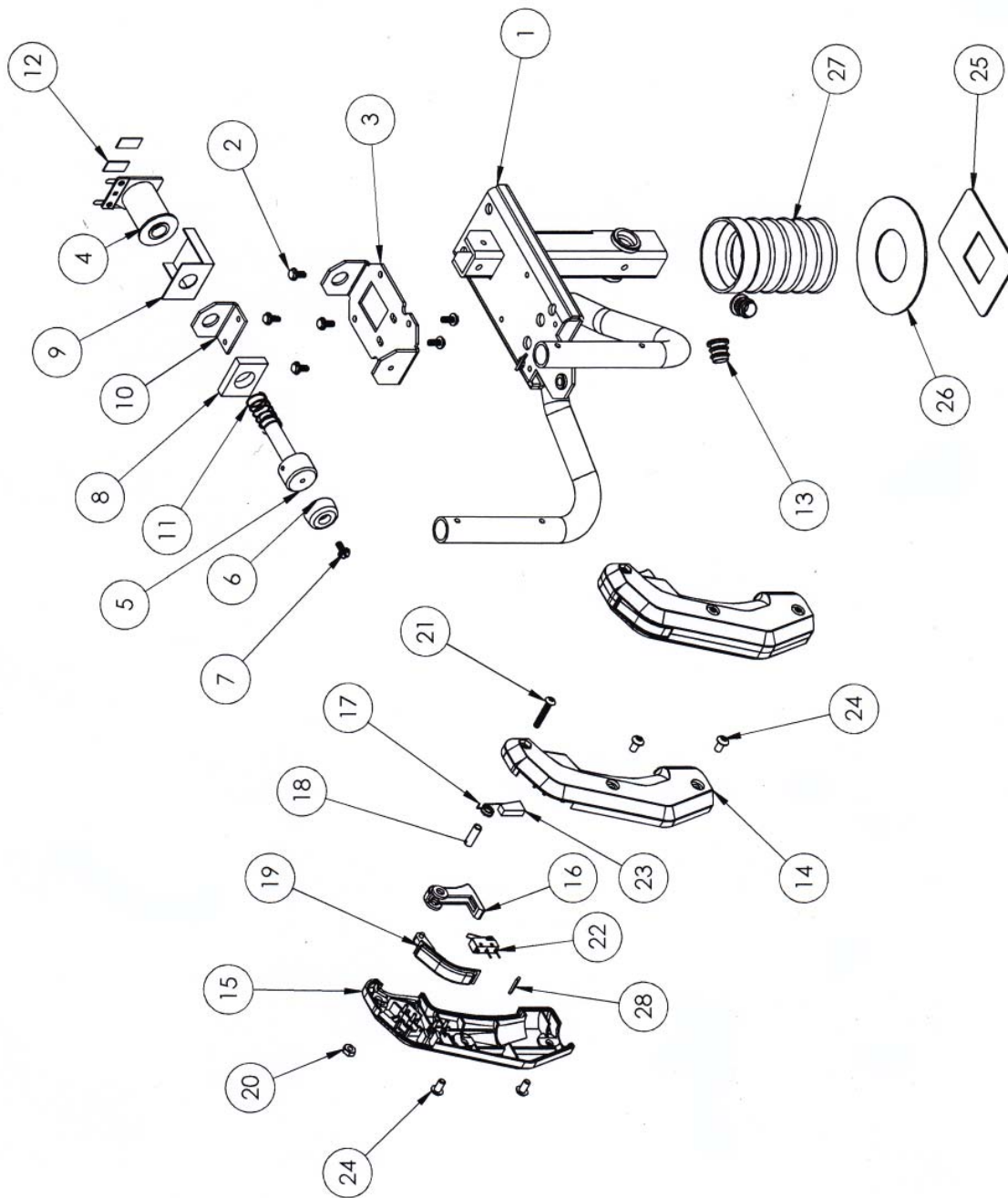

FIGURE 2

Part	Part #	Part Name
1	601-11815	Dual Handled Welded Painted F/Sega Analog Gun
2		Screw, #8-32 x3/8 HEX Head
3	601-11826	Bracket Coil Mounting F/Sega Analog Gun
4	601-11827	Coil with Tubing
5	601-11828	Plunger F/Solenoid
6	601-11829	Bumper Solenoid Stop
7		Screw #8-32x3/8 HEX Washer Head MS wiht SEMS
8	601-11830	Rear Bumper Pad
9	601-11831	Insulator
10		Coil Retaining Bracket
11	601-11832	Spring Compression
12		Pad Adhesive Foam Tape
13		Tube Plug .49 to .59 I.D. MMC #9283k11
14	601-11816	Grip, Right Half
15	601-11817	Grip, Left Half
16	601-11818	Trigger Red
17	601-11819	Spring, Torsion
18	601-11820	Shaft, Trigger
19		Large Thumb Button, Gray
20	601-11821	Nut, Hex #8-32
21	601-11822	Screw #8-32 x1 PBHMS
22	601-11823	Switch Assy. WMS DA3 Type
23	601-11824	Trigger Bumper
24	601-11825	Screw, 10-32 x3/8 B.H. TORX T-20 T. PRF
25	99-10-100	Disc Plastic Washer
26	99-10-100	Round AntiPinch Washer .50"ID x 3.375OD x .62THK
27	99-10-100	Rubber Bellow For Sega Analog Gun
28		Metal Spacer for Thumb Button Anti Movement

FIGURE 3

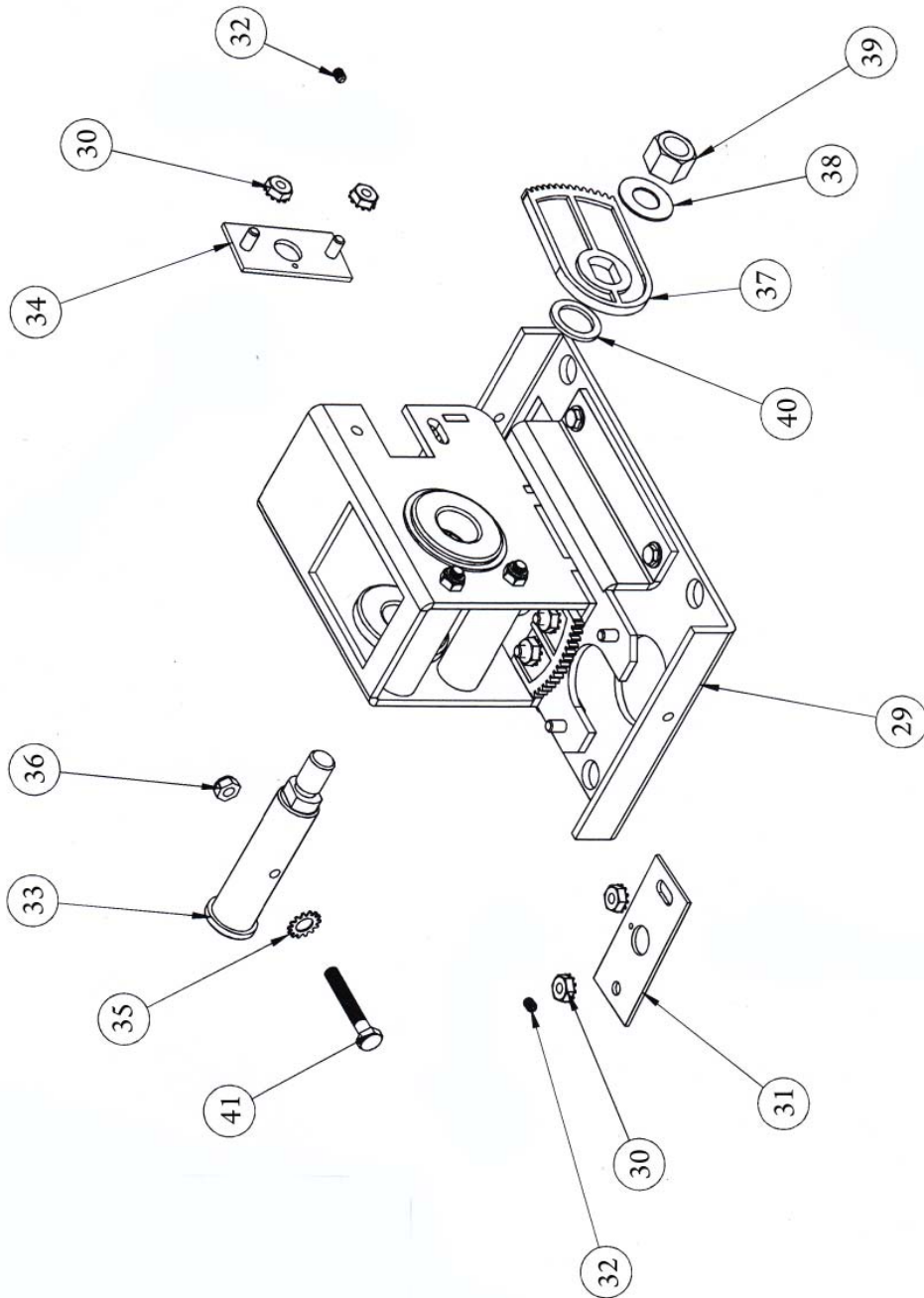

FIGURE 3

Part	Part #	Part Name
29		Bottom & Base Brkt SubAssy with Bumper Gun Assy
30		Nut, KEPS 8-32
31		Bracket Pot MTG Horizontal
32		Set Screw 6-32 x 3/16 Cup Point
33		Shaft 5/8 Diameter
34		Bracket Pot MTG Vertical
35		Lockwasher #10 External Zinc Plated
36		Nut HEX 10-32 Jame Nylock Zinc Plated
37	601-11839	Gear Segment W/Hub
38		3/8 SAE Flat Washer Zinc Plated
39		Nut 3/8-16 Nylock
40		Spacer Segment Gear
41		Hex Head Cap Screw 10/31x 1 1/4

13

PARTS LIST

PARTS LIST cont.

Computers and Boards

FIGURE 4

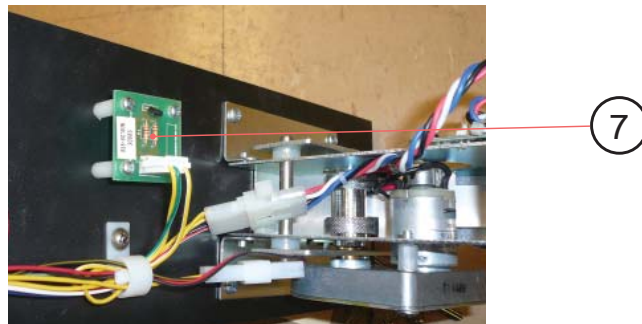
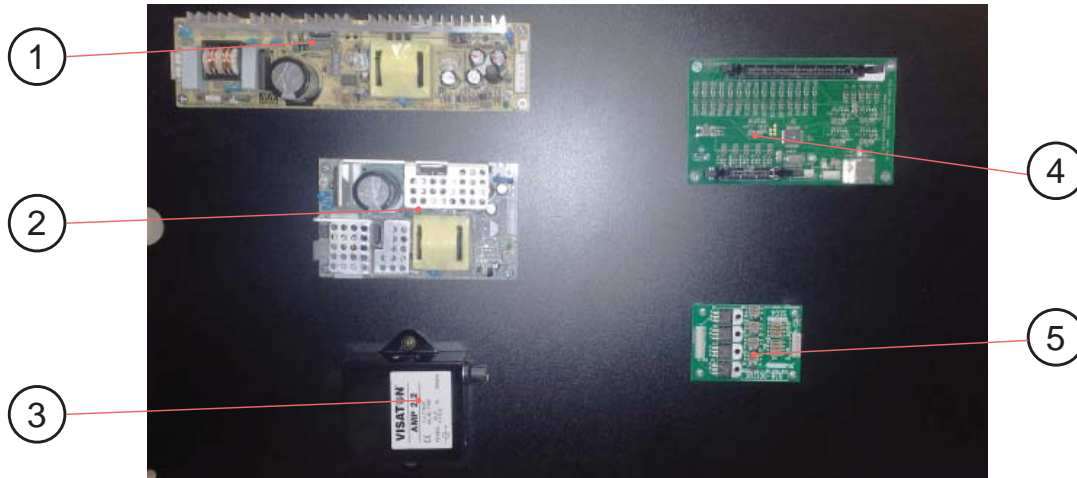
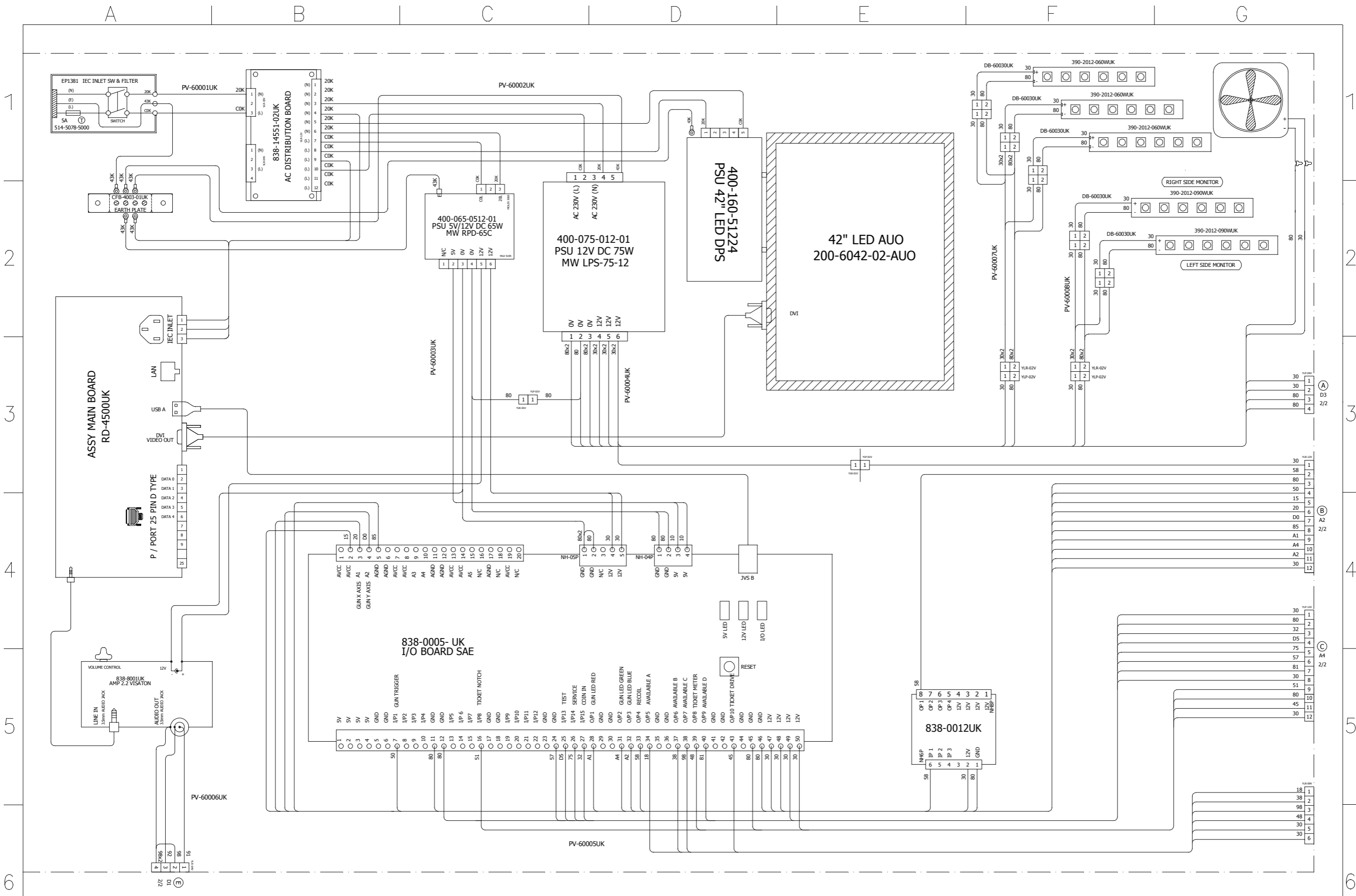

FIGURE 4

Part	Part #	Part Name
1	838-8001-UK	Power Supply
2	400-065-0512-01	Power Supply
3	400-075-012-01	Sound Amp
4	838-0012UK	Solenoid Driver
5	838-0005UK	I/O Board
6	RD-4500UK	Main CPU
7	838-0015UK	Ticket Vend Board

14 SCHEMATIC DIAGRAMS



8	BLACK	E	LIGHT GREEN	4.3	EARTH WIRE							
7	ORANGE			?	AWG18	UL1672						
5	WHITE	C	PURPLE	?	AWG20	UL1672						
4	GREEN		BROWN	U	AWG16	UL1015						
3	YELLOW	B	SKY BLUE	K	AWG18	UL1015						
2	BLUE	A	PINK	L	AWG20	UL1007						
1	RED	9	GRAY	T	AWG22	UL1007						
					AWG24	UL1007						

ALTERATION												

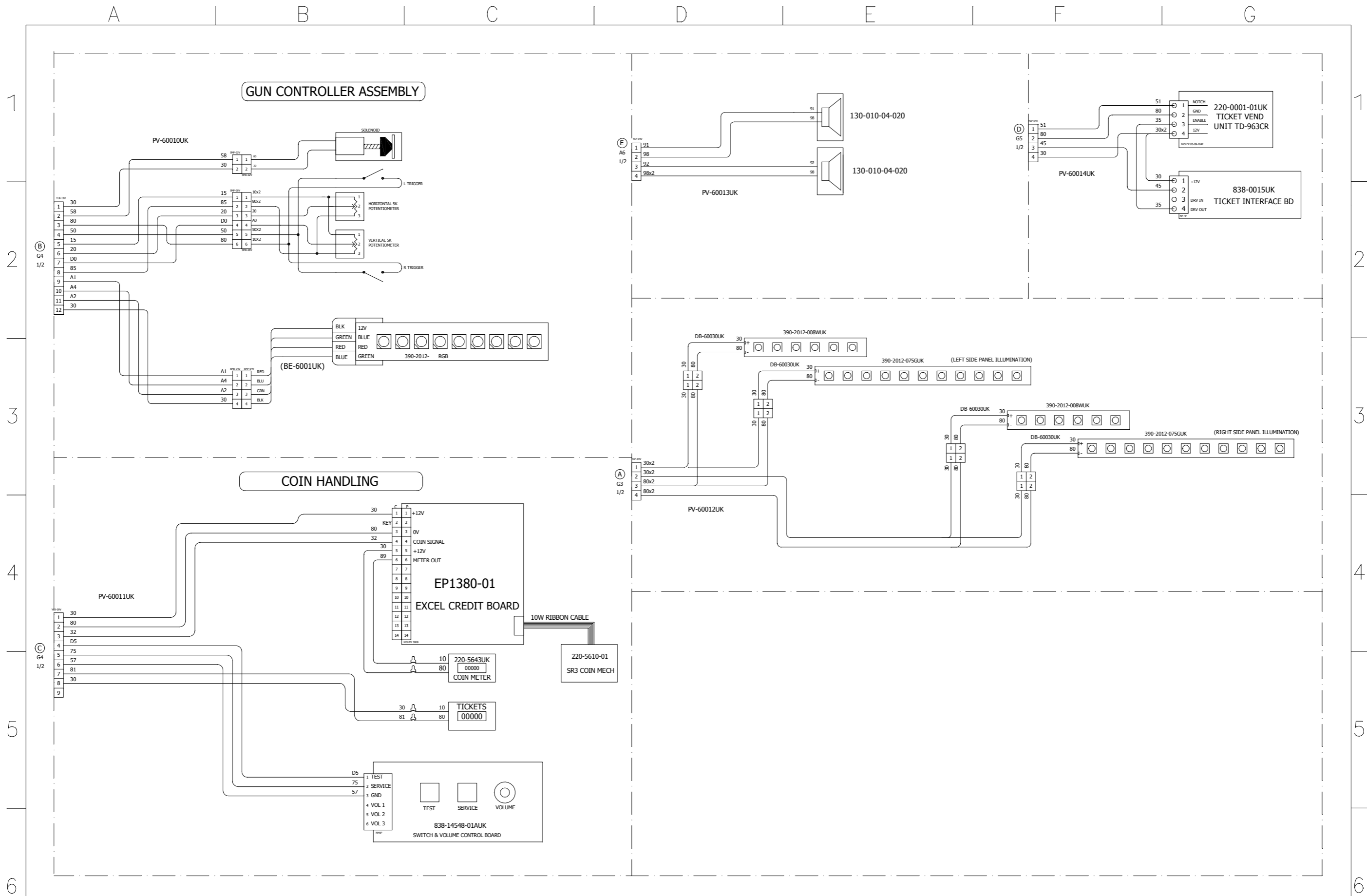

8	BLACK	E	LIGHT GREEN	4.3	EARTH WIRE
7	ORANGE	D	PURPLE	?	AWG18 UL1672
5	WHITE	C	BROWN	?	AWG20 UL1672
4	GREEN	B	SKY BLUE	U	AWG16 UL1015
3	YELLOW	A	PINK	K	AWG18 UL1015
2	BLUE	9	GRAY	L	AWG20 UL1007
1	RED			T	AWG22 UL1007

PZ-0000UK	DR	RA			
	DATE	09/08/2013			
PART NUMBER					

SEGA AMUSEMENTS EUROPE LTD	THIS DRAWING WILL IN NO WAY BE COPIED, TO BE RETURNED ON DEMAND.
PLANTS vs. ZOMBIES VIDEO REDEMPTION	ORIGINAL SIZE A2
DESCRIPTION	

1st PRINTING



Sega Amusements Europe Limited.
42 Barwell Business Park, Leatherhead Road, Chessington, Surrey, KT9 2NY. United Kingdom.
Telephone: +44 (0) 208 391 8090 Facsimile: +44 (0) 208 391 8099
email: mailbox@sega.co.uk Web: <http://www.segaarcade.com>

Play It! Amusements, inc.
252 Beinoris Drive, Wood Dale, IL. 60191, USA
USA Sales: +00 (1) 224 265 4287

© SEGA